



ATR144

Controller / Regolatore



User manual / Manuale d'uso
Installationsanleitung / Manuel utilisateur

Table of contents

1	Safety guidelines	10
1.1	Organization of safety notices	10
1.2	Safety Precautions	11
1.3	Precautions for safe use	11
1.4	Environmental policy / WEEE	13
2	Model identification	13
3	Technical data	13
3.1	General features	13
3.2	Hardware features	14
3.3	Programming mode	15
4	Dimensions and installation	16
5	Electrical wirings	16
5.1	Wiring diagram	17
5.1.a	Power supply	18
5.1.b	Analogue input AI1	18
5.1.c	Examples of connection for linear input .. 20	
5.1.d	Digital input 1	21
5.1.e	Digital input 2	21
5.1.f	Serial input (only on ATR144-AD-T)	21
5.1.g	Digital output	21
5.1.h	Relay output Q1	21
5.1.i	Relay output Q2 (only on ATR144-AD)	22
6	Display and key functions	22
6.1	Meaning of status lights (Led)	22
6.2	Keys	23
7	Controller Functions	24
7.1	Modification of main and alarm setpoint value	24
7.2	Automatic Tune	24
7.3	Manual Tune	24
7.4	Tuning performed once	25
7.5	Synchronized Tuning	26
7.6	Digital input functions	27
7.7	Automatic / Manual regulation for % output control	29
7.8	Loop Break	29
7.9	Dual Action (Heating-Cooling)	30

7.10	Funzione LATCH ON.....	32
7.11	Soft start function.....	33
7.12	Pre-programmed cycle.....	34
7.13	Timer functions.....	35
8	Serial communication.....	36
8.1	Slave.....	36
8.2	Serial compatibility with ATR121-ADT.....	44
8.3	Serial compatibility with ATR142-AD-T.....	46
8.4	Master.....	49
8.4.a	Master mode in retransmission.....	49
8.4.b	Master Mode Remote process.....	51
8.4.c	Master reading mode CT 2000.35.014...	51
8.4.d	Master reading mode CT 2000.35.014 as amperometer.....	52
9	Reading and configuration through NFC.....	52
9.1	Config. through memory card.....	54
9.2	Creation / update memory card.....	54
9.3	Loading config. from memory card.....	54
10	Loading default values.....	55
11	Access configuration.....	55
11.1	Parameters list functioning.....	56
12	Table of Configuration Parameters.....	57
13	Alarm Intervention Modes.....	94
13.a	Absolute or threshold alarm active over (par. 62 <i>AL.IF.</i> = <i>Ab.uPA</i>).....	94
13.b	Absolute or threshold alarm active below (par. 62 <i>AL.IF.</i> = <i>Ab.LoA</i>).....	94
13.c	Absolute or threshold alarm referred to command setpoint active over (par. 62 <i>AL.IF.</i> = <i>Ab.c.uA</i>).....	95
13.d	Absolute or threshold alarm referred to command setpoint active below (par. 62 <i>AL.IF.</i> = <i>Ab.c.LA</i>).....	95
13.e	Band alarm (par. 62 <i>AL.IF.</i> = <i>bAnd</i>).....	96
13.f	Asymmetric band alarm (par. 62 <i>AL.IF.</i> = <i>AbAnd</i>).....	97
13.g	Upper deviation alarm (par. 62 <i>AL.IF.</i> = <i>uPdEu</i>).....	97
13.h	Lower deviation alarm (par. 62 <i>AL.IF.</i> = <i>Lo.dEu</i>).....	98
13.1	Alarms label.....	99
14	Table of anomaly signals.....	100

Indice degli argomenti

1	Norme di sicurezza.....	109
1.1	Organizzazione delle note di sicurezza	110
1.2	Note di sicurezza	110
1.3	Precauzioni per l'uso sicuro.....	111
1.4	Tutela ambientale e smaltimento dei rifiuti / Direttiva WEEE.....	113
2	Identificazione del modello.....	113
3	Dati tecnici.....	113
3.1	Caratteristiche generali.....	113
3.2	Caratteristiche Hardware	114
3.3	Modalità di programmazione.....	115
4	Dimensioni e installazione	116
5	Collegamenti elettrici.....	116
5.1	Schema di collegamento	117
5.1.a	Alimentazione	118
5.1.b	Ingresso analogico AI1	118
5.1.c	Esempi di collegamento per ingressi normalizzati.....	120
5.1.d	Ingresso digitale 1.....	121
5.1.e	Ingresso digitale 2.....	121
5.1.f	Ingresso seriale (solo ATR144-AD-T)	121
5.1.g	Uscita digitale.....	121
5.1.h	Uscita relè Q1.....	121
6	Funzione dei visualizzatori e tasti.....	122
6.1	Significato delle spie di stato (Led)	122
6.2	Tasti.....	123
7	Funzioni del regolatore.....	124
7.1	Modifica valore setpoint principale e di allarme.....	124
7.2	Tuning automatico	124
7.3	Tuning manuale	125
7.4	Tuning once	125
7.5	Tuning sincronizzato.....	126
7.6	Funzioni da Ingresso digitale.....	127
7.7	Regolazione automatico / manuale del controllo % uscita.....	129
7.8	Loop Break	130

7.9	Funzionamento in doppia azione (caldo-freddo)...	
	131	
7.10	Funzione LATCH ON.....	133
7.11	Funzione Soft-Start.....	134
7.12	Ciclo pre-programmato.....	135
7.13	Funzioni timer.....	135
8	Comunicazione Seriale.....	137
8.1	Slave.....	137
8.2	Compatibilità seriale con ATR121-ADT.....	146
8.3	Compatibilità seriale con ATR142-AD-T.....	148
8.4	Master.....	151
	8.4.a Modalità master in ritrasmissione.....	151
	8.4.b Modalità master processo remoto.....	153
	8.4.c Modalità master lettura CT 2000.35.014..	153
	8.4.d Modalità master lettura CT 2000.35.014	
	come amperometro.....	153
9	Lettura e configurazione via NFC.....	154
9.1	Configurazione tramite memory card.....	155
9.2	Creazione / aggiornamento della memory card.....	156
9.3	Caricamento configurazione da memory card.....	156
10	Caricamento valori di default.....	157
11	Accesso alla configurazione.....	157
11.1	Funzionamento della lista parametri.....	158
12	Tabella parametri di configurazione.....	159
13	Modi d'intervento allarme.....	195
13.a	Allarme assoluto o allarme di soglia attivo sopra (par. 62	
	RL.IF. = Ab.uPA).....	195
13.b	Allarme assoluto o allarme di soglia attivo sotto (par. 62	
	RL.IF. = Ab.Lo.A).....	196
13.c	Allarme assoluto o allarme di soglia riferito al setpoint di	
	comando attivo sopra (par. 62 RL.IF. = Ab.c.uA).....	196
13.d	Allarme assoluto o allarme di soglia riferito al setpoint di	
	comando attivo sotto (par. 62 RL.IF. = Ab.c.LA).....	197
13.e	Allarme di Banda (par. 62 RL.IF. = bAnd).....	197
13.f	Allarme di banda asimmetrica (par. 62 RL.IF. = Ab.bAnd).....	198
13.g	Allarme di deviazione superiore (par. 62 RL.IF. = uP.dEu).....	198

13.h	Allarme di deviazione inferiore (par. 62 RL IF = Lo.dEu)....	199
13.1	Label allarmi	200
14	Tabella segnalazioni anomalie	200

Themenverzeichnis

1	Sicherheitsvorschriften.....	207
1.1	Bedeutung der Sicherheitshinweise.....	208
1.2	Sicherheitshinweise.....	208
1.3	Bestimmungsgemäße Verwendung	209
1.4	Umweltschutz und Entsorgung / WEEE-Richtlinie ..	211
2	Hinweise zum Modell	211
3	Technische Daten	211
3.1	Allgemeine Spezifikationen	211
3.2	Hardware-Spezifikationen	212
3.3	Programmierung	213
4	Abmessungen und Installation	214
5	Elektrischer Anschluss.....	214
5.1	Schaltplan.....	215
5.1.a	Spannungsversorgung.....	216
5.1.b	Analogeingang AI1	216
5.1.c	Anschlussbeispiele für Normeingänge.....	217
5.1.d	Digital Eingang 1	218
5.1.e	Digital Eingang 2	219
5.1.f	Serieller Eingang (nur für ATR144-AD-T)...	219
5.1.g	Digitalausgang	219
5.1.h	Ausgang Relais Q1	219
5.1.i	Ausgang Relais Q2 (nur für ATR144-AD) ...	219
6	Funktion der Anzeigen und Tasten.....	220
6.1	Statusanzeigen (Led).....	220
6.2	Tasten	220
7	Funktionen des Reglers.....	221
7.1	Änderung des Haupt- und Alarm-Sollwertes	221
7.2	Automatische Tuning-Funktion.....	222
7.3	Manuelle Tuning-Funktion.....	222

7.4	Tuning once	223
7.5	Tuning synchronisiert	223
7.6	Funktionen über den Digitaleingang.....	224
7.7	Automatische/manuelle Regulierung der Kontrolle % am Ausgang.....	226
7.8	Loop Break	227
7.9	Doppelfunktion (Heizen-Kühlen)	228
7.10	Funktion LATCH ON.....	230
7.11	Funktion Soft-Start	232
7.12	Vorprogrammierter Zyklus.....	232
7.13	Funktion timer	233
8	Serielle Kommunikation	235
8.1	Slave.....	235
8.2	Serielle Kompatibilität mit ATR121-ADT.....	244
8.3	Serielle Kompatibilität mit ATR142-AD-T.....	246
8.4	Master	249
8.4.a	Mastermodus bei Neuübertragung.....	249
8.4.b	Mastermodus Remote-Istwert	252
8.4.c	Mastermodus Ablesen CT 2000.35.014.....	252
8.4.d	Mastermodus Ablesen CT 2000.35.014 als Stromwandler.....	252
9	Ablesen und Konfiguration über NFC	253
9.1	Konfiguration über die USB-Speicherkarte	255
9.2	Erstellung und Aktualisierung der Speicherkarte....	255
9.3	Laden der Konfiguration von Speicherkarte.....	256
10	Laden der Werkseinstellung.....	256
11	Zugang zur Konfiguration	257
11.1	Funktionsweise der Parameterliste	258
12	Tabelle der Konfigurationsparameter	259
13	Alarmauslösung	296
13.a	Absolutalarm oder Schwellenalarm, aktiv darüber (par. 62 RL IF = Ab.uPA)	296
13.b	Absolutalarm oder Schwellenalarm, aktiv darunter (par. 62 RL IF = Ab.LoA)	297
13.c	Absolutalarm oder Schwellenalarm bezogen auf Regelsol- lwert, aktiv darüber (par. 62 RL IF = Ab.c.uA).....	297

13.d	Absolutalarm oder Schwellenalarm bezogen auf Regelsollwert, aktiv darunter (par. 62 RL I.F. = Ab.c.L.A.)	298
13.e	Bereichsalarm (par. 62 RL I.F. = bAnd)	298
13.f	Asymmetrischer Bereichsalarm (par. 62 RL I.F. = A.bAnd) ..	299
13.g	Oberer Abweichungsalarm (par. 62 RL I.F. = uP.dEu)	299
13.h	Unterer Abweichungsalarm (par. 62 RL I.F. = Lo.dEu)	300
13.1	Alarmmeldungen.....	300
14	Tabelle der Fehlermeldungen	301

Table des contenus

1	Consignes de sécurité	309
1.1	Organisation des avis de sécurité.....	309
1.2	Avis de sécurité.....	310
1.3	Précautions pour l'usage en toute sécurité	310
1.4	Politique environnementale / DEEE	312
2	Identification du modèle.....	312
3	Données techniques.....	313
3.1	Caractéristiques générales	313
3.2	Caractéristiques Hardware.....	313
3.3	Caractéristiques Software	314
3.4	Mode de programmation	314
4	Dimensions et Installation	315
5	Raccordements électriques	316
5.1	Plan des connexions.....	317
5.1.a	Alimentation	317
5.1.b	Entrée analogique AI1	318
5.1.c	Exemples de connexion pour les entrées standard.....	319
5.1.d	Entrée digitale 1.....	320
5.1.e	Entrée digitale 2.....	321
5.1.f	Entrée sérielle (seulement ATR144-AD-T) . 321	
5.1.g	Sortie digitale.....	321
5.1.h	Sortie relai Q1.....	321
5.1.i	Sortie relai Q2 (seulement ATR144-AD).....	321

1 Safety guidelines

Read carefully the safety guidelines and programming instructions contained in this manual before connecting/using the device.

Disconnect power supply before proceeding to hardware settings or electrical wirings to avoid risk of electric shock, fire, malfunction.

Do not install/operate the device in environments with flammable/explosive gases.

This device has been designed and conceived for industrial environments and applications that rely on proper safety conditions in accordance with national and international regulations on labour and personal safety. Any application that might lead to serious physical damage/ life risk or involve medical life support devices should be avoided.

Device is not conceived for applications related to nuclear power plants, weapon systems, flight control, mass transportation systems.

Only qualified personnel should be allowed to use device and/or service it and only in accordance to technical data listed in this manual. Do not dismantle/modify/repair any internal component. Device must be installed and can operate only within the allowed environmental conditions. Overheating may lead to risk of fire and can shorten the lifecycle of electronic components.

1.1 Organization of safety notices

Safety notices in this manual are organized as follows:

Safety notice	Description
Danger!	Disregarding these safety guidelines and notices can be life-threatening.
Warning!	Disregarding these safety guidelines and notices can result in severe injury or substantial damage to property.
Information!	This information is important for preventing errors.

1.2 Safety Precautions

Danger!	CAUTION - Risk of Fire and Electric Shock. This product is UL listed as open type process control equipment. It must be mounted in an enclosure that does not allow fire to escape externally.
Danger!	If the output relays are used past their life expectancy, contact fusing or burning may occasionally occur. Always consider the application conditions and use the output relays within their rated load and electrical life expectancy. The life expectancy of output relays varies considerably with the output load and switching conditions.
Warning!	Loose screws may occasionally result in fire. For screw terminals tighten screws to tightening torque of 0,5 Nm.
Warning!	A malfunction in the Digital Controller may occasionally make control operations impossible or prevent alarm outputs, resulting in property damage. To maintain safety in the event of malfunction of the Digital Controller, take appropriate safety measures, such as installing a monitoring device on a separate line.

1.3 Precautions for safe use

Be sure to observe the following precautions to prevent operation failure, malfunction, or adverse affects on the performance and functions of the product. Not doing so may occasionally result in unexpected events. Do not handle the Digital Controller in ways that exceed the ratings.

- The product is designed for indoor use only. Do not use or store the product outdoors or in any of the following places.
 - Places directly subject to heat radiated from heating equipment.
 - Places subject to splashing liquid or oil atmosphere.

- Places subject to direct sunlight.
- Places subject to dust or corrosive gas (in particular, sulfide gas and ammonia gas).
- Places subject to intense temperature change.
- Places subject to icing and condensation.
- Places subject to vibration and large shocks.
- Installing two or more controllers in close proximity might lead to increased internal temperature and this might shorten the life cycle of electronic components. It is strongly recommended to install cooling fans or other air-conditioning devices inside the control cabinet.
- Always check the terminal names and polarity and be sure to wire properly. Do not wire the terminals that are not used.
- To avoid inductive noise, keep the controller wiring away from power cables that carry high voltages or large currents. Also, do not wire power lines together with or parallel to Digital Controller wiring. Using shielded cables and using separate conduits or ducts is recommended. Attach a surge suppressor or noise filter to peripheral devices that generate noise (in particular motors, transformers, solenoids, magnetic coils or other equipment that have an inductance component). When a noise filter is used at the power supply, first check the voltage or current, and attach the noise filter as close as possible to the Digital Controller. Allow as much space as possible between the Digital Controller and devices that generate powerful high frequencies (high-frequency welders, high-frequency sewing machines, etc.) or surge.
- A switch or circuit breaker must be provided close to device. The switch or circuit breaker must be within easy reach of the operator, and must be marked as a disconnecting means for the controller.
- The device must be protected by a fuse 1A (cl. 9.6.2).
- Wipe off any dirt from the Digital Controller with a soft dry cloth. Never use thinners, benzine, alcohol, or any cleaners that contain these or other organic solvents.

- Deformation or discoloration may occur.
- The number of non-volatile memory write operations is limited. Therefore, use EEPROM write mode when frequently overwriting data, e.g.: through communications.

1.4 Environmental policy / WEEE

Do not dispose electric tools together with household waste material. According to European Directive 2012/19/EU on waste electrical and electronic equipment and its implementation in accordance with national law, electric tools that have reached the end of their life must be collected separately and returned to an environmentally compatible recycling facility.

2 Model identification

The ATR144 series includes 4 versions:

Power supply 24..230 VAC/VDC $\pm 15\%$ 50/60 Hz – 5 Watt	
ATR144-ABC	1 analogue input + 2 relays 5 A + 1 D.I/O
ATR144-ABC-T	1 analogue input + 1 relays 5 A + 1 D.I/O + RS485
Power supply 12..24 VAC/VDC $\pm 10\%$ 50/60 Hz – 5 Watt (5.5 Watt for AD-T)	
ATR144-AD	1 analogue input + 2 relays 5 A + 1 D.I/O
ATR144-AD-T	1 analogue input + 1 relays 5 A + 1 D.I/O + RS485

3 Technical data

3.1 General features

Displays	4 digits 9.6 mm (0.38 pollici), 5 digits 7.1 mm (0.28 pollici)
Operative conditions	Temperature: 0-45° C - Humidity 35..95 uR% Max. altitude: 2000m
Sealing	IP65 front panel (with gasket) IP20 box and terminals
Materials	Box and front panel: PC UL94V2 self-extinguishing
Weight	Approx. 120 g

3.2 Hardware features

Analogue input	<p>AI1: Configurable via software. Input: Thermocouple type K, S, R, J, T, E, N, B. Automatic compensation of cold junction from -25...85° C. Thermoresistances: PT100, PT500, PT1000, Ni100, Ni120, PTC 1K, NTC 10K (β 3435K and β3694K), NTC 2252 (β3976K) Input V/mA: 0-1 V, 0-5 V, 0-10 V, 0-20 o 4-20 mA, 0-60 mV. Pot. Input: 1...150 KΩ.</p>	<p>Tolerance (25° C) $\pm 0.2\% \pm 1$ digit (on F.s.) for thermocouple, thermoresistance and V/mA. Cold junction accuracy 0.1° C/°C.</p> <p>Impedence: 0-10 V: Ri>110 KΩ 0-20 mA: Ri<5 Ω 0-40 mV: Ri>1 MΩ</p>
Relay outputs	Configurable as command and alarm output.	<p>Contacts: 5 A - 250 VAC Resistive load.</p>
SSR outputs	Configurable as command and alarm output.	<p>12 V, 25 mA. Min. load 1 mA</p>

ATR144-ABC e ATR144-ABC-T

Power supply	<p>Extended power-supply 24..230 VAC/VDC $\pm 15\%$ 50/60 Hz Overvoltage category: II</p>	Consumption: 5 Watt
--------------	--	---------------------

ATR144-AD e ATR144-AD-T

Power supply	<p>Extended power-supply 12..24 VAC/VDC $\pm 10\%$ 50/60 Hz Overvoltage category: II</p>	<p>Consumption: 5 Watt (5.5 Watt for ATR144-AD-T)</p>
--------------	---	---

Software features

Regulation algorithms	ON-OFF with hysteresis. P, PI, PID, PD with proportional time
Proportional band	0..9999°C o °F
Integral time	0,0..999,9 sec (0 exclude)
Derivative time	0,0..999,9 sec (0 exclude)
Controller functions	Manual or automatic Tuning, selectable alarm, protection of command and alarm setpoints.

3.3 Programming mode

by keyboard	..see paragraph 11
software LabSoftview	..on "Download section" of official pixsys site: www.pixsys.net
App MyPixsys	..through download the App on Google Play Store®, see paragraph 9 When activated by a reader/interrogator supporting NFC-V protocol, controller ATR144 is to be considered a VICC (Vicinity Inductively Coupled Card) according to ISO/IEC 15693 and it operates at a frequency of 13.56 MHz. The device does not intentionally emit radio waves.

The controller is designed and conceived to be incorporated into other machines, therefore CE marking on the controller does not exempt the manufacturer of machines from safety and conformity requirements applying to the machine itself.

- Wiring ATR144, use crimped tube terminals or flexible/rigid copper wire with diameter 0.14 to 1.5 mm² (min. AWG26, max. AWG16). Cable stripping length is 7 mm.
- It is possible to connect on a single terminal two wires with same diameter comprised between 0.14 and 0.75mm².

5.1 Wiring diagram

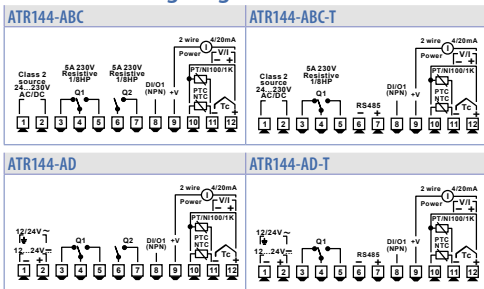

5.1.a Power supply

ATR144-ABC and ATR144-ABC-T

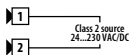

Switching power supply 24..230 VAC/
VDC $\pm 15\%$ 50/60 Hz - 5 Watt.
Galvanic insulation.

ATR144-AD and ATR144-AD-T

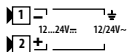

Switching power supply 12..24 VAC/
VDC $\pm 10\%$ 50/60 Hz - 5 Watt (5.5 Watt for
ATR144-AD-T).
Galvanic insulation.

5.1.b Analogue input AI1

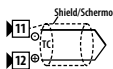

For thermocouples K, S, R, J, T, E, N, B.

- Comply with polarity
- For possible extensions, use compensated cable and terminals suitable for the thermocouples used (compensated).
- When shielded cable is used, it should be grounded at one side only.

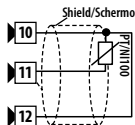

For thermoresistances PT100, Ni100.

- For the three-wire connection use wires with the same section.
- For the two-wire connection short-circuit terminals 10 and 12.
- When shielded cable is used, it should be grounded at one side only.



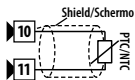

For thermoresistances NTC, PTC, PT500, PT1000 and linear potentiometers.

- When shielded cable is used, it should be grounded at one side only to avoid ground loop currents.

ATR144-ABC and ATR144-ABC-T

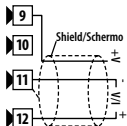

For linear signals in Volt and mA

- Comply with polarity
- When shielded cable is used, it should be grounded at one side only to avoid ground loop currents.

ATR144-AD and ATR144-AD-T

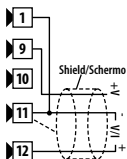

For linear signals in Volt and mA

- Comply with polarity
- When shielded cable is used, it should be grounded at one side only to avoid ground loop currents.
- For 2- and/or 3-wire sensors short pin 1 and pin 11.

5.1.c Examples of connection for linear input

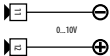
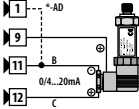
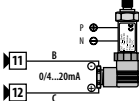
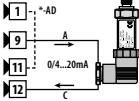
	<p>For signals 0..10V</p> <ul style="list-style-type: none"> Comply with polarity
	<p>For signals 0/4..20mA with three-wire sensor</p> <ul style="list-style-type: none"> Comply with polarity <p>C = Sensor output B = Sensor ground A = Sensor power supply (12V/30mA)</p> <p>* for -AD versions short pin1 and pin 11</p> <p>In the picture: pressure sensor.</p>
	<p>For signals 0/4..20mA with external power of sensor</p> <ul style="list-style-type: none"> Comply with polarity <p>C = Sensor output B = Sensor ground</p> <p>In the picture: pressure sensor. Connect the external power supply to pins P and N.</p>
	<p>For signals 0/4..20mA with two-wire sensor</p> <ul style="list-style-type: none"> Comply with polarity <p>C = Sensor output A = Sensor power supply (12V/30mA)</p> <p>* for -AD versions short pin1 and pin 11</p> <p>In the picture: pressure sensor.</p>

5.1.d Digital input 1



Digital input can be enabled by parameter.
Close pin 8 "DI/O1" on pin 9 "+V" to enable digital input.

5.1.e Digital input 2



Digital input can be enabled by parameter. Not available when a resistive sensor (thermoresistances or potentiometers) is selected.
Close pin 10 on pin 11 to enable digital input.

5.1.f Serial input (only on ATR144-AD-T)

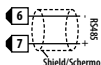

Modbus RS485 communication.
RTU Slave with galvanic insulation.
It is recommended to use the twisted and shielded cable for communications.

5.1.g Digital output



Digital output NPN (including SSR) for command or alarm.
Range 12 VDC/25 mA.

5.1.h Relay output Q1

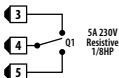

Capacity 5 A / 250 VAC for resistive loads.

5.1.i Relay output Q2 (only on ATR144-AD)

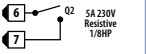
	<p>Capacity 5 A / 250 VAC for resistive loads.</p>
--	--





6 Display and key functions

	<p>1 1234</p>	<p>Normally displays the process. During the configuration phase, it displays the parameter groups or the parameter being inserted.</p>
	<p>2 Probe</p>	<p>Normally displays the setpoint. During the configuration phase, it displays the parameter value being inserted.</p>

6.1 Meaning of status lights (Led)

3	C	ON when the command output 1 is active. In case of motorized valve control it is ON during valve opening and flashes during valve closing.
4	A1	ON when alarm 1 is active.
5	A2	ON when alarm 2 is active.
6	T	ON when the controller is executing an auto-tuning cycle.
7	M	ON when "Manual" function is active.
8	R	ON when the controller communicates through serial. Flashes when the remote setpoint is enabled.



6.2 Keys

9		<ul style="list-style-type: none">• Increases the main setpoint.• During configuration allows to scroll the parameters or the groups of parameters.• Increases the setpoints.
10		<ul style="list-style-type: none">• Decreases the main setpoint.• During configuration allows to scroll the parameters or the groups of parameters.• Decreases the setpoints.
11		<ul style="list-style-type: none">• Allows to visualize command and alarm setpoints.• During configuration allows to enter the parameter to be modified and confirms the variation.
12		<ul style="list-style-type: none">• Allows to enter the Tuning launch function, automatic/manual selection.• During configuration works as exit key (ESCAPE).

7 Controller Functions

7.1 Modification of main and alarm setpoint value

Setpoint value can be modified from keyboard as follows:

	Press	Display	Do
1		Value on display 2 changes.	Increases or decreases the main setpoint value.
2		Visualizes the other setpoints on display 1. Display 2 shows the setpoint type.	
3		Value on display 1 changes.	Increases or decreases the alarm setpoint value.

7.2 Automatic Tune

Automatic tuning procedure allows a precise regulation without detailed knowledge of PID regulation algorithm. Selecting Auto on par. 36 *ΕΥΝ.Ι*, the controller analyzes the proces oscillations and optimizes the PID parameters.

Led T flashes. If the PID parameters are not yet selected, at the device switch-on, the manual tunig procedure described in the next paragraph will be launched described into the next paragraph.

7.3 Manual Tune

Manual procedure allows the user greater flexibility to decide when to update

PID algorithm parameters. During the manual tuning, the device generates a step to analyze the system inertia to be regulated and, according to the collected data, modifies PID parameters.

After selecting *ΜΑΝ.Ι* on par. 36 *ΕΥΝ.Ι*, the procedure can be activated in three ways:

- **Running Tuning by keyboard:**
Press FNC until display 2 shows t_{unE} with display 1 on d_{i5} . and then press SET: display 1 shows E_{nRb} . Led T switches ON and the procedure starts.
- **Running Tuning by digital input:**
Select t_{unE} on par. 94 d_{i1F} . or on par. 101 d_{i2F} . At first activation of digital input (commutation on front panel) led T led switches on and at second activation switches off.
- **Running Tuning by serial input:**
Write 1 on word modbus 1210: led T switches ON and the procedure starts. Write 0 to stop the tuning.

To avoid an overshoot, the threshold where the controller calculates new PID parameters is determined by this operation:

Tune threshold = Setpoint - "Set Deviation Tune" (par. 37 $S_{d.t.l}$)

Ex.: if the setpoint is 100.0 °C and the Par. 37 $S_{d.t.l}$ is 20.0 °C the threshold to calculate PID parameters is $(100.0 - 20.0) = 80.0$ °C.

For a greater precision on PID parameters calculation it is suggested to start the manual tuning procedure when the process is not close to setpoint value.

7.4 Tuning performed once

Set o_{ncE} on parameter 36 $t_{un.l}$.

Autotuning procedure is executed only once at next ATR144 restart. If the procedure doesn't work, it will be executed at next restart.

7.5 Synchronized Tuning

Set *Synch.* on parameter 36 *tun.l.*

This procedure has been conceived to calculate correct PID values on multi-zone systems, where each temperature is influenced by the adjacent zones.

Writing on word modbus 1210 the controller works as follows:

Word value	Action
0	Tune off
1	Command output OFF
2	Command output ON
3	Tune active
4	Tune completed: command output OFF (read only)
5	Tune not available: softstart function enabled (only reading)

Here below the functioning for regulation loop: the master switches-off or turns-on all zones (value 1 or 2 on word 1210) for a time long enough to create inertia on the system.

At this point the autotuning is launched (value 3 on word 1210). The controller executes the procedure for the calculation of the new PID values. When the procedure ends, the controller switches off the command output and selects the value 4 on word 1210. The Master, always reading word 1210, will control the various zones and when all will have finished, it will set to 0 the value of word 1210: the various devices will regulate the temperature independently, with the new calculated values.

■ N.B. The master must read the word 1210 at least every 10 seconds or the controller will automatically exit the autotuning procedure.

7.6 Digital input functions

The ATR144 functions related to digital inputs can be enabled by parameters 94 *d. i. 1F.* and 101 *d. i. 2F.*

- *2t5U.*: Two threshold setpoint modification: with digital input active the ATR144 regulates on SET2, otherwise it regulates on SET1;
- *2t5U. i.*: Modification of 2 setpoints by digital input with impulse command;
- *3t5U. i.*: Modification of 3 setpoints by digital input with impulse command,
- *4t5U. i.*: Modification of 4 setpoints by digital input with impulse command,
- *5t.r5t.*: Start / Stop of the controller by digital input with impulse command. Status of the controller, upon power-up, depends on parameter 30 *in i.5* ;
- *run.*: The regulation is enabled only with digital input active. With the controller in STOP the alarms remain active.
- *EHt.AL.*: when the digital input is active, the controller goes on STOP and the alarms will be disabled. The controller does not return to START automatically: for this operation, the user's intervention is required (turning the ATR144 off and on again, or activating the digital input set to *5t.r5t.*, or pressing the SET button if the parameter 130 *5.t.5F.* is set to *5t.r5t.*, or start from serial port).
- *Hold.*: With digital input active the conversion is locked (visualization maintenance function);
- *tunE*: Enables/disables the Tuning if par. 36 *tun.l* is set on *PARU*;
- *RU.PA. i.*: If par. 29 *A.PA.l* is selected as *EnAb.* or *En.5to.*, with impulse command on digital input, the ATR144 switches the related regulation loop, from automatic to manual and vice versa.
- *RU.PA. c.*: If par. 29 *A.PA.l* is selected as *EnAb.* or *En.5to.* the ATR144 switches to manual the related regulation loop, with digital input active, otherwise the regulation is automatic.



- *Rc.t.ty*: The ATR144 execute a cooling type regulation with digital input active, otherwise the regulation is of heating type;
- *R.t. 0*: Zero tare function: brings the related analogue input to 0.
- *PrES*: Allows the reset of the command and alarm outputs if manual reset is active.
- *t.1.run*: If timer 1 is enabled (par. 186 *tPr.1* different from *d.5Ab*), with digital input active, the timer is switched to RUN, otherwise is kept in STOP;
- *t.1S.E*: If timer 1 is enabled (par. 186 *tPr.1* different from *d.5Ab*), acting on the digital input, the status of the timer switches from STOP to RUN e vice versa;
- *t.1StA*: If il timer 1 is enabled (par. 186 *tPr.1* different from *d.5Ab*), acting on the digital input, the timer is switched to RUN;
- *t.1End*: If il timer 1 is enabled (par. 186 *tPr.1* different from *d.5Ab*), acting on the digital input, the timer is switched to STOP;
- *t.2.run*: If timer 2 is enabled (par. 189 *tPr.2* different from *d.5Ab*), with digital input active, the timer is switched to RUN, otherwise is kept in STOP;
- *t.2S.E*: If timer 2 is enabled (par. 189 *tPr.2* different from *d.5Ab*), acting on the digital input, the status of the timer switches from STOP to RUN e vice versa;
- *t.2StA*: If timer 2 is enabled (par. 189 *tPr.2* different from *d.5Ab*), acting on the digital input, the timer is switched to RUN;
- *t.2End*: If timer 2 is enabled (par. 189 *tPr.2* different from *d.5Ab*), acting on the digital input, the timer is switched to STOP;
- *Lo.cFL*: With digital input active, the access to setpoint configuration/modification is locked;
- *uP.tEY*: simulates the operation of the up button.
- *doUn.t*: simulates the operation of the down button.
- *Fnc .t*: simulates the operation of the FNC button.
- *SEt .t*: simulates the operation of the SET button.

7.7 Automatic / Manual regulation for % output control

This function allows to switch from automatic functioning to manual command of the output percentage. The cycle time is set in parameter 45 c.t. 1 ("Cycle Time 1").

With par. 29 $R.A.I$ it is possible to select two modes.

1 **First selection** ($E.n.A.b$) allows to enable with FNC the writing $P.---$ on display 1, while on display 2 is showed $R.u.t.o.n$.

Press SET to visualize $n.A.n.u$; it's now possible, during the process visualization, modify through the keys  and  the output percentage. To back to automatic, with the same procedure, select $R.u.t.o.n$. on display 2: immediately led M switches off and functioning backs to automatic.

2 **Second selection** ($E.n.S.t.o$) enables the same functioning but with two important variants:

- If there is a temporary power failure or after switch-off, the manual functioning as well as the previous output percentage value will be maintained at restarting.
- If the sensor breaks during automatic functioning, the controller switches to manual mode while maintaining the output percentage command unchanged as generated by the PID immediately before breakage.

Ex: on an extruder the command in percentage of the resistance (load) is maintained also in case of input sensor failure.

7.8 Loop Break

The function Loop Break allows to detect a failure on the control loop. During activation of the actuator, the process is supposed to change towards the setpoint. If this change is not consistent or fast enough, ATR144 will display the message "loop break alarm". This message won't be shown if parameter 62 or 78 are set to "L.B.A" - in this case the regulator generates an alarm, enables the corresponding output and displays the message selected in the parameter 72 ("alarm 1 label") or 88 ("alarm 2 label").

This is only a software control and it only occurs in the output saturation phase (control percentage 0% or 100%); it should not be mistaken with a partial or total failure of the load, which is measured, for example, using a current transformer. Setting manu. in the parameter 141 L.b.5. ("Loop Break State"), the controller checks if the process has changed at least by the value set in the parameter 143 L.b.b. ("Loop Break Band"), in a maximum time equal to the value of the parameter 142 L.b.t. ("Loop Break Time").

If you set autom. in the parameter 141 L.b.5 ("Loop Break State"), the values concerning time and change of control are calculated automatically, but only if the setting action is made by PID, PI or PD.

The band will assume a value of $0.5 \cdot P_b$, and the time will be $2 \cdot T_i$ in case of PID or PI setting, or $12 \cdot T_d$ in case of PD setting.

7.9 Dual Action (Heating-Cooling)

ATR144 is suitable also for systems requiring a combined heating-cooling action. The command output has to be configured as PID for Heating (Par. 19 A.c.t.1 = HEAT and P.b. 1 greater than 0), and one of the alarms (AL.1.F. or AL.5.F.) has to be configured as COOL. The command output must be connected to the actuator responsible for heating, while the alarm will control cooling action.

Parameters to be configured for the heating PID are:

A.c.t.1 = HEAT Command output action type (Heating);

P.b. 1 or P.b. 2: Heating proportional band;

i.t. 1 or i.t. 2: Integral time of heating and cooling;

d.t. 1 or d.t. 2: Derivative time of heating and cooling;

c.t. 1 or c.t. 2: Heating time cycle.

Parameters to be configured for the cooling PID related to regulation loop 1 and alarm 1 are:

AL.1.F. = COOL Alarm 1 selection (Cooling);

P.b.1.f: Proportional band multiplier;

o.d.b.f: Overlapping / Dead band;

c.c.t.f: Cooling time cycle.

Par. $P.b.\overline{n}.l$ (that ranges from 1.00 to 5.00) determines the proportional band of cooling action basing on the formula:

Proportional band for cooling action = $P.b. l \times P.b.\overline{n}.l$

This gives a proportional band for cooling which will be the same as heating band if $P.b.\overline{n}.l = 1.00$, or 5 times greater if $P.b.\overline{n}.l = 5.00$.

Integral and derivative time are the same for both actions.

Par. $\sigma.d.b.l$ determines the percentage overlapping between the two actions. For systems in which the heating output and cooling output must never be simultaneously active a Dead Band ($\sigma.d.b.l \leq 0$), must be configured, vice versa you can configure an overlapping ($\sigma.d.b.l > 0$).

The following figure shows an example of dual action PID (heating-cooling) with $i.t. l = 0$ e $d.t. l = 0$.

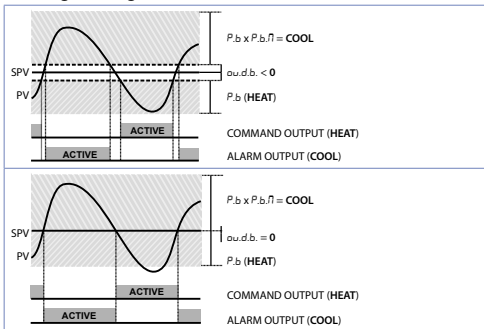

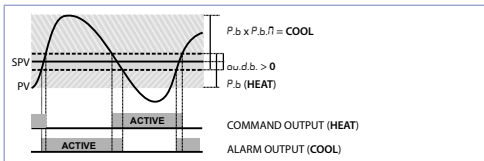

Parameter $c.c.t.l$ has the same meaning of cycle time for heating action $c.c.t.l$.

Parameter $co.F.l$ (Cooling Fluid) pre-selects the proportional band multiplier $P.b.n.l$ and the cooling PID cycle time $c.c.t.l$ according to cooling fluid type:

$co.F.l$	Cooling fluid type	$P.b.n.l$	$c.c.t.l$
Air	Air	1.00	10
Oil	Oil	1.25	4
H ₂ O	Water	2.50	2

Once parameter $co.F.l$ has been selected, the parameters $P.b.n.l$, $o.d.b.l$ and $c.c.t.l$ can be however modified.

7.10 Funzione LATCH ON

For use with input $P.o.t.$ and with linear input (0..10 V, 0..40 mV, 0/4..20 mA) it is possible to associate start value of the scale (par. 4 $l.l.l.i.l$) to the minimum position of the sensor and value of the scale end (par. 5 $u.l.i.l$) to the maximum position of the sensor (par. 10 $l.t.c.l$ configured as $5.t.n.d.r$).

It is also possible to fix the point in which the controller will display 0 (however keeping the scale range between $l.l.l.i.l$ and $u.l.i.l$) using the "virtual zero" option by selecting $u.o.s.t.o.$ or $u.o.t.o.n.$ on par. 10 $l.t.c.l$. Selecting $u.o.t.o.n.$ the virtual zero must be reset at each restart; selecting $u.o.s.t.o.$ the virtual zero will remain fixed once calibrated. To use the LATCH ON function, configure the par. $l.t.c.l$.

Then refer to the following table for the calibration procedure:

	Press	Display	Do
1	FNC	Exit parameters configuration. Display 2 visualizes writing $LALc$.	Place the sensor on minimum operating value (corresponding to $L.L. i. l$)
2	▼	Store value on minimum. Display shows $L0U$.	Place sensor on maximum operating value (corresponding to $u.L. i. l$).
3	▲	Store value on max. Display shows $H iUh$.	To exit standard proceeding press SET . For "virtual zero" setting, place the sensor to zero point.
4	FNC	Set virtual zero. Display shows $ZEra$. If "Virtual zero at start" is selected, point 4 must be repeated at each starting.	To exit procedure press SET .



7.11 Soft start function

ATR144 is provided with two types of softstart selectable on parameter 110 $SS.tY$. ("Softstart Type").

- 1 First selection ($GrAd$) enables gradient softstart. At starting the controller reaches setpoint basing on the rising gradient set on parameter 111 $SS.Gr$. ("Softstart Gradient") in Unit/hour (ex. °C/h). If parameter 114 $SS.t i$. ("Softstart Time") is different to 0, at starting when the time selected on par. 114 $SS.t i$. is elapsed, the controller stops to follow the gradient and reaches setpoint with the maximum power.

- 2 Second selection (PE_{rc}) enables output percentual softstart. On par. 113 SS_{tH} it is possible to set the threshold under which starts the softstart ("Softstart Threshold"). On par. 112 SS_{PE} ("Softstart Percentage") an output percentage is selectable (from 0 to 100), which controller keeps until the process exceeds the threshold set on par. 113 SS_{tH} or until the time in minutes set on par. 114 SS_{t} ("Softstart Time").

If the Sof-Start function is active the automatic/manual Tuning function cannot be activated.

7.12 Pre-programmed cycle

Pre-programmed cycle function activates by setting EN_{AB} on parameter 109 P_{rc} .

Controller reaches setpoint 1 basing on the gradient set on parameter 111 SS_{Gr} , then it reaches max. power up to setpoint 2. When the process reaches max. power, this setpoint is maintained for the time set on parameter 115 MA_{t} .

At expiry, process will reach ambient temperature according to gradient entered on parameter 116 FA_{Gr} , then command output will be disabled and display will visualize St_{OP} .

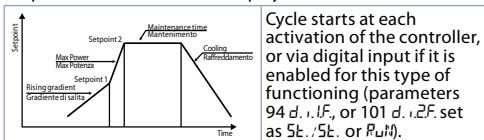

7.13 Timer functions

The ATR144 integrates two timers that can be independent, sequential or looped together.

Timer 1 is enabled on parameter 186 *tPr.1*; timer 2 on parameter 189 *tPr.2*:



- ENRb.* the timer starts from the keyboard or digital input (user intervention is required)
- ENStR.* the timer starts counting when the regulator is in RUN.

The timer time-base set in *Pr.55* or *hh.Pr* by changing parameters 187 *t.b.t.1* for timer 1 and 190 *t.b.t.2* for timer 2.

In parameter 192 *tPr.5* can be define whether the timers should be independent or related to each other.

- SINGL.* The timers work independently of each other.
- SEQUe.* When timer 1 ends, timer 2 starts. The sequence is active only by starting timer 1. When timer 2 expires, the sequence is interrupted.
- LoopP* When a timer ends, another starts: the sequence repeats itself cyclically.

To change the duration of the counting time, follow the steps below:

	Press	Display	Do
1		Press until <i>tPr. 1</i> or <i>tPr. 2</i> visualized on display 1.	
2		Digits on display 1 changes.	Increase or decrease time value for the selected timer (00:00 ... 99:59).

To start the keyboard count follow the steps below:

	Press	Display	Do
1	FNC	Press until $t_{1n.1}$ or $t_{1n.2}$ visualized on display 2. Display 1 shows STOP if the timer is stopped, otherwise it shows the remaining time.	
2	SET	The timer stops if active or starts counting if in STOP.	

Start/Stop of Timer is possible also by digital input (see parameters $d_{1.F} \dots d_{2.F}$). The alarm outputs can be associated with the timers (parameters $AL_{1.F} \dots AL_{2.F}$). On parameters 188 $AL_{1.1}$ and 191 $AL_{1.2}$ is possible to select the activation mode. The proposed solutions are as follows:

$SEPRt$	Alarm active during timer counting
ENd	Alarm active when the timer expiry
$WPRt$	Alarm active 5" before the timer expiry

8 Serial communication

8.1 Slave

ATR144-xxx-T is equipped with RS485 and can receive/broadcast data via serial communication using MODBUS RTU protocol. The device can only be configured as a Slave by setting Enab. on parameter 149 $nb_{.5L}$. This function enables the control of multiple controllers connected to a supervisory system / SCADA.

Each controller responds to a Master query only if the query contains the same address as parameter 150 SL_{Ad} ("Slave Address"). The addresses permitted range from 1 to 254 and there must not be controllers with the same address on the same line. Address 255 can be used by the Master to communicate with all the connected equipment (broadcast mode), while with 0 all the devices receive the command, but no response is expected.

The baud rate is selected on parameter 151 $SL_{b.r}$ ("Slave Baud Rate"). The serial format is set on parameter 152 $SL_{S.P.F}$ ("Slave Serial Port Format")

ATR144 can introduce a delay (in milliseconds) of the response to the master request. This delay must be set on parameter 153 *SE.dE*. ("*Serial Delay*").

Each parameter modification is saved by the controller in the EEPROM memory (100000 writing cycles), while the setpoints are saved with a delay of 10 seconds after the last modification. Changes made to words that are different from those reported in the following table can lead to malfunction.



Modbus RTU protocol features	
Baud-rate	Selectable on parameter 151 <i>SL.b.r.</i> 1200bit/s 28800bit/s 2400bit/s 38400bit/s 4800bit/s 57600bit/s 9600bit/s 115200bit/s 19200bit/s
Format	Selectable on parameter 152 <i>SS.PF.</i> 8N1 8N2 8E1 8E2 8O1 8O2
Supported functions	WORD READING (max 50 word) (0x03, 0x04) SINGLE WORD WRITING (0x06) MULTIPLE WORDS WRITING (max 50 word) (0x10)

Here below a list of all available addresses and supported functions:

RO = Read Only	R/W = Read/Write	WO = Write Only
----------------	------------------	-----------------

Modbus address	Description	Read Write	Reset value
0	Device type	RO	53x
1	Software version	RO	Flash
2	Boot version	RO	Flash
3	Slave Address	RO	Eepr/dip
6	Baud rate	RO	Eepr/dip
50	Slave address automatic learning	WO	-
51	System code comparison for slave address automatic learning	WO	-
500	Loading default values (write 9999)	RW	0
501	Restart ATR144 (write 9999)	RW	0
502	Setpoint storing delay time	RW	10
503	Parameters storing delay time	RW	1
701	First character of the custom alarm message 1	RW	"u"
...		RW	-
723	Last character of the custom alarm message 1	RW	0
751	First character of the custom alarm message 2	RW	"u"
...		RW	-
773	Last character of the custom alarm message 2	RW	0
1000	All value (degrees with tenth)	RO	-
1001	Real setpoint (gradient)	RO	0
1002	Alarms status (0=absent, 1=present) Bit0 = Alarm 1 Bit1 = Alarm 2	RO	0

Modbus address	Description	Read Write	Reset value
1003	Error flags 1 Bit0 = AI1 process error (sensor 1) Bit1 = Cold junction error Bit2 = Safety error Bit3 = Generic error Bit4 = Hardware error Bit5 = Errore L.B. Bit6 = Parameters out of range error Bit7= CPU eeprom writing error Bit8= RFid eeprom writing error Bit9= CPU eeprom reading error Bit10= RFid eeprom reading error Bit11= Eeprom calibrations bench corrupted Bit12= Eeprom constants bench corrupted Bit13 = Missing calibrations error Bit14 = Eeprom CPU bench parameters corrupted Bit15 = Eeprom CPU setpoint bench corrupted	RO	0
1004	Error flags 2 Bit0 = RFid memory not formatted Bit1 = Eeprom CPU logo bench corrupted Bit2 = Modbus Master error	RO	0
1005	Digital inputs status (0=not active, 1=active) Bit0 = Digital input 1 Bit1 = Digital input 2	RO	0
1006	Outputs status (0=off, 1=on) Bit 0 = Q1 Bit 1 = Q2 Bit 4 = DO1	RO	0

Modbus address	Description	Read Write	Reset value
1007	Led status (0=off, 1=on) Bit 0 = Led C Bit 1 = Led T Bit 2 = Led R Bit 3 = Led A1 Bit 4 = Led A2 Bit 5 = Led M Bit 7 = Led point time 2 Bit 8 = Led point time 1	RO	0
1008	Key status (0=released, 1=pressed) Bit 0 = Key  arrow Bit 1 = Key  arrow Bit 2 = Key FNC Bit 3 = Key SET	RO	0
1009	Cold junction temperature (degrees with tenth)	RO	-
1100	All value with decimal point selection	RO	-
1101	Real setpoint (gradiente) with decimal point selection	RO	0
1200	Setpoint 1 of regulation loop 1 (degrees with tenth)	R/W	EEPROM
1201	Setpoint 2 of regulation loop 1 (degrees with tenth)	R/W	EEPROM
1202	Setpoint 3 of regulation loop 1 (degrees with tenth)	R/W	EEPROM
1203	Setpoint 4 of regulation loop 1 (degrees with tenth)	R/W	EEPROM
1204	Alarm 1 setpoint (degrees with tenth) Alarm 1 setpoint upper if Par. 62 <i>AL. I.F. = R.bAnd</i>	R/W	EEPROM

Modbus address	Description	Read Write	Reset value
1205	Alarm 1 setpoint lower if Par. 62 <i>AL.LF. = A.bAnd</i> (degrees with tenth)	R/W	EEPROM
1206	Alarm 2 setpoint (degrees with tenth) Alarm 2 setpoint upper if Par. 78 <i>AL.ZF. = A.bAnd</i>	R/W	EEPROM
1207	Alarm 2 setpoint lower if Par. 78 <i>AL.ZF. = A.bAnd</i> (degrees with tenth)	R/W	EEPROM
1208	Start/Stop 0=controller in STOP 1=controller in START	R/W	0
1209	Hold conversion ON/OFF 0=Hold conversion OFF 1=Hold conversion ON	R/W	0
1210	Tune management		
	With automatic Tune (par. 36 <i>tun.l = Auto</i>): 0=autotuning function OFF 1=autotuning ON	RO	0
	With manual Tune (par. 36 <i>tun.l = Manual</i>): 0=autotuning function OFF 1=autotuning ON	R/W	0
	With synchronized Tune (par. 36 <i>tun.l = SyncH</i>): 0=autotuning function OFF 1=command output OFF (forces the cooling) 2=command output ON (forces the heating) 3=autotuning ON 4=autotuning ended	R/W	0

Modbus address	Description	Read Write	Reset value
1211	Automatic/manual selection 0=automatic; 1=manual	R/W	0
1212	Command output percentage (0-10000) Heating output percentage with regulation in double loop (0-10000)	R/W	0
1213	Command output percentage (0-1000) Heating output percentage with regulation in double loop (0-1000)	R/W	0
1214	Command output percentage (0-100) Heating output percentage with regulation in double loop (0-100)	R/W	0
1215	Cooling output percentage with regulation in double loop (0-10000)	RO	0
1216	Cooling output percentage with regulation in double loop (0-1000)	RO	0
1217	Cooling output percentage with regulation in double loop (0-100)	RO	0
1218	Command output manual reset: write 0 to reset the command output. In reading 0=reset not allowed, 1=reset allowed	R/W	0
1219	Alarms manual reset: write 0 to reset all alarms. In reading 0=reset not allowed, 1=reset allowed Bit0 = Alarm 1 Bit1 = Alarm 2	R/W	0
1220	Alarm 1 remote status (0=absent, 1=present)	R/W	0

Modbus address	Description	Read Write	Reset value
1221	Alarm 2 remote status (0=absent, 1=present)	R/W	0
1222	Tare of zero AI1 (1=tare; 2=reset tare)	R/W	0
1300	Setpoint 1 of regulation loop 1, with decimal point selection	R/W	EEPROM
1301	Setpoint 2 of regulation loop 1, with decimal point selection	R/W	EEPROM
1302	Setpoint 3 of regulation loop 1, with decimal point selection	R/W	EEPROM
1303	Setpoint 4 of regulation loop 1, with decimal point selection	R/W	EEPROM
1304	Alarm 1 setpoint, with decimal point selection Alarm 1 upper setpoint if Par. 62 $RLIF = RbR_{nd}$	R/W	EEPROM
1305	Alarm 1 lower setpoint if Par. 62 $RLIF = RbR_{nd}$, with decimal point selection	R/W	EEPROM
1306	Alarm 2 setpoint, with decimal point selection Alarm 2 upper setpoint if Par. 78 $RLZF = RbR_{nd}$	R/W	EEPROM
1307	Alarm 2 lower setpoint if Par. 78 $RLZF = RbR_{nd}$, with decimal point selection	R/W	EEPROM
1400	Remote process reset: by writing 1, the ATR144 uses for the process the value measured by the analogue input instead of the one written in the word 1401	W	-

Modbus address	Description	Read Write	Reset value
1401	Remote process. The number written in this word will be the process value that the device uses for setting and alarms (ADC disabled)	W	-
2001	Parameter 1	R/W	EEPROM
2002	Parameter 2	R/W	EEPROM
...	Parameter ...	R/W	EEPROM
2223	Parameter 223	R/W	EEPROM

8.2 Serial compatibility with ATR121-ADT

In existing plants where it is necessary to replace an ATR121-AD-T, it is possible to install a new ATR144-xxx-T enabling the Modbus registers' compatibility.

To enable the Modbus registers' compatibility with the ATR121, simply enter the password 0121.

To return again to the ATR144 Modbus mapping, enter the password 0144.

The new register map is the following:

Modbus address	Description	Read Write	Reset value
0	Device type	R	101/102
1	Software version	R	?
2	Reserved	R	-
3	Reserved	R	-
4	Reserved	R	0
5	Slave Address	R	EEPR
6	Reserved	R	-
50	Indirizzamento automatico	WO	-

51	Confronto codice impianto	WO	-
500	Loading default values (write 9999)	R/W	0
1000	Process	R	0
1001	Cold junction	R	0
1002	Setpoint 1	R/W	EEPR
1003	Setpoint 2	R/W	EEPR
1004	Heating output percentage (0-10000)	R	0
1005	Cooling output percentage (0-10000)	R	0
1006	Relays status (0=off, 1=on) Bit 0 = Q1 relay Bit 1 = Q2 relay Bit 2 = SSR	R/W	0
1007	Manual reset. Write 1 to reset all the alarms	R/W	0
1008	Error flags Bit0 = Eeprom writing error Bit1 = Eeprom reading error Bit2 = Cold junction error Bit3 = Process error (sensor) Bit4 = Generic error Bit5 = Missing calibration data	R	0
1009	Start/Stop 0 = controller in STOP 1 = controller in START	R/W	0
1010	OFF LINE * time (milliseconds)	R/W	0
2001	Par. 1 $c.out - c.out$	R/W	EEPR
2002	Par. 2 $5E_n - 5E_n$	R/W	EEPR
2003	Par. 3 $d.P. - d.P$	R/W	EEPR
2011	Par. 11 $rEG - rEG$	R/W	EEPR
2012	Par. 12 $S.c.c. - S.c.c.$	R/W	EEPR
2013	Par. 13 $LdI - LEdI$	R/W	EEPR

2015	Par. 15 <i>P.b. - P.b.</i>	R/W	EEPR
2016	Par. 16 <i>t.i. - t.i.</i>	R/W	EEPR
2017	Par. 17 <i>t.d. - t.d.</i>	R/W	EEPR
2018	Par. 18 <i>t.c. - t.c.</i>	R/W	EEPR
2019	Par. 19 <i>AL - AL</i>	R/W	EEPR
2020	Par. 20 <i>c.r.A - c.r. A.</i>	R/W	EEPR
2021	Par. 21 <i>S.c.A - S.c.A.</i>	R/W	EEPR
2022	Par. 22 <i>Ld² - LEd²</i>	R/W	EEPR
2027	Par. 27 <i>t.un - t.unE</i>	R/W	EEPR

8.3 Serial compatibility with ATR142-AD-T

In existing plants where it is necessary to replace an ATR142-AD-T, it is possible to install a new ATR144-xxx-T enabling the Modbus registers' compatibility.

To enable the Modbus registers' compatibility with the ATR142, simply enter the password 0142.

To return again to the ATR144 Modbus mapping, enter the password 0144.

The new register map is the following:

Modbus address	Description	Read Write	Reset value
0	Device type	RO	EEPROM
1	Software version	RO	EEPROM
5	Slave Address	R/W	EEPROM
6	Boot version	RO	EEPROM
50	Automatic addressing	WO	-
51	System code comparison	WO	-

500	Loading default values: 9999 restore all values 9998 restore all values except for baud-rate and slave address 9997 restore all values except for slave address 9996 restore all values except for baud-rate	WO	0
1000	Process (with tenths of degree for temperature sensors; digits for linear sensors)	RO	-
1001	Setpoint1	R/W	EEPROM
1002	Setpoint2	R/W	EEPROM
1003	Setpoint3	R/W	EEPROM
1004	Setpoint4	R/W	EEPROM
1005	Alarm1	R/W	EEPROM
1006	Alarm2	R/W	EEPROM
1007	Setpoint gradient	RO	EEPROM
1008	Outputs status (0=off, 1=on) Bit 0 = Q1 relay Bit 1 = Q2 relay Bit 2 = SSR	RO	0
1009	Heating output percentage (0-10000)	RO	0
1010	Cooling output percentage (0-10000)	RO	0
1011	Alarms status (0=none, 1=active) Bit0 = Alarm 1 Bit1 = Alarm 2	RO	0
1012	Manual reset: write 0 to reset all the alarms. In reading (0=not resettable, 1=resettable): Bit0 = Alarm 1 Bit1 = Alarm 2	WO	0

1013	Error flags Bit0 = Eeprom writing error Bit1 = Eeprom reading error Bit2 = Cold junction error Bit3 = Process error (sensor) Bit4 = Generic error Bit5 = Hardware error Bit6 = Master off-line Bit7 = Missing calibration data	RO	0
1014	Cold junction temperature (tenths of degree)	RO	-
1015	Start/Stop 0=controller in STOP 1=controller in START	R/W	0
1016	Lock conversion ON/OFF 0=Lock conversion off 1=Lock conversion on	R/W	0
1017	Tuning ON/OFF 0=Tuning off 1=Tuning on	R/W	0
1018	Automatic/manual selection 0=automatic 1=manual	R/W	0
1019	OFF LINE* time (milliseconds)	R/W	0
1020	Process visualized (decimal as display)	RO	0
1100	Visualized Setpoint 1 (decimal as display)	RO	-
1101	Visualized Setpoint 1 (decimal as display)	R/W	EEPROM
1102	Visualized Setpoint 2 (decimal as display)	R/W	EEPROM
1103	Visualized Setpoint 3 (decimal as display)	R/W	EEPROM
1104	Visualized Setpoint 4 (decimal as display)	R/W	EEPROM

1105	Visualized Alarm 1 (decimal as display)	R/W	EEPROM
1106	Visualized Alarm 2 (decimal as display)	R/W	EEPROM
1107	Setpoint gradient (decimal as display)	RO	EEPROM
1108	Heating output percent. (0-1000)	RO	0
1109	Heating output percent. (0-100)	RO	0
1110	Cooling output percent. (0-1000)	RO	0
1111	Cooling output percentage (0-100)	RO	0

* If value is 0, the control is disabled. If different from 0, it is the max. time which can elapse between two pollings before the controller goes off-line. If it goes off-line, the controller returns to Stop mode, the control output is disabled but the alarms are active.

8.4 Master

The device works as master if value selected on parameter 160 *MA* is other than *SLAVE*.

8.4.a Master mode in retransmission

In this mode the device may write up to two values on a target (slave) with ID equal to the value set on the parameter 161 *TA* ("Target Address"). BaudRate and serial format will have to be set on the parameters 162 *MBR* ("Master Baud Rate") and 163 *MSPF* ("Master Serial Port Format"). The variables to be resent are chosen on the parameters 164 *VAR1* and 169 *VAR2*: the addresses for reading/writing the variables should be set on the parameter 165 *V1A* ("Variable 1 Address") for variable 1 and parameter 170 *V2A* ("Variable 2 Address") for variable 2. For resending the setpoints (parameters 164 *VAR1* or 169 *VAR2* set to *RWCSE* or *RWRIS*.) after writing on the slave, the ATR144 starts reading the word that has been chosen: in this way any change of the slave value is also registered by the master. Two subsequent queries are delayed by the

time set on the parameter 174 *t_{r.dE}*. ("Transmission Delay"), while the response from the slave is expected for a max. time set on the parameter 175 *r_{E.tO}*. ("Reception Timeout"). The following table shows the choices which allow the master operation during resending.

<i>uAr.1</i> or <i>uAr.2</i>	Description
<i>U.Pro.</i> Write Process	Write the process value
<i>r.U.c.5E.</i> Read/Write Command Setpoint	Read and Write the command setpoint value
<i>U.c.o.u.P.</i> Write Command Output Percentage	Write the output percentage calculated by the P.I.D. (Range 0-10000)
<i>r.U.A.1S.</i> Read/Write Alarm 1 Setpoint	Read and Write the alarm 1 setpoint value
<i>U.conS.</i> Write Constant	Write the parameter value 168 <i>con.1</i> or 173 <i>con.2</i>

The read/written value might be rescaled according to the proportion described in the following table:

<i>uAr.1</i> or <i>uAr.2</i>	Value limits input		Limits of rescaled value	
	Min	Max	Min	Max
<i>U.Pro.</i> Write Process	<i>LL.1.1</i> Lower Limit Input 1	<i>UL.1.1</i> Upper Limit Input 1	<i>LL.u.1o</i> <i>LL.u.2</i> Lower Limit Variable x	<i>UL.u.1o</i> <i>UL.u.2</i> Upper Limit Variable x
<i>r.U.c.5E.</i> Read/Write Command Setpoint	<i>LLS.1</i> Lower Limit Command Setpoint	<i>ULS.1</i> Upper Limit Command Setpoint	<i>LL.u.1o</i> <i>LL.u.2</i> Lower Limit Variable x	<i>UL.u.1o</i> <i>UL.u.2</i> Upper Limit Variable x

<i>U.C.O.U.P.</i> Write Command Output Percentage	0	10000	<i>LL.U.10</i> <i>LL.U.2</i> Lower Limit Variable x	<i>u.L.U.10</i> <i>u.L.U.2</i> Upper Limit Variable x
<i>r.U.A.15.</i> Read/Write Alarm 1 Setpoint	<i>A.L.L.</i> Alarm 1 Lower Limit	<i>A.I.U.L.</i> Alarm 1 Upper Limit	<i>LL.U.10</i> <i>LL.U.2</i> Lower Limit Variable x	<i>u.L.U.10</i> <i>u.L.U.2</i> Upper Limit Variable x

The input value (included between minimum and max limit) is linearly converted into the retransmitted value which is included between min and max output value. Rescaling is not executed if parameters *LL.U.1* e *u.L.U.1* or *LL.U.2* have the same value.

8.4.b Master Mode Remote process

To enable this function it is necessary to select *r.Pro.* on parameter 164 *uAr.l*. In this mode the ATR144 reads a value remotely and sets it as a process. The read value might be rescaled according to the proportion described in the following table:

<i>PARSE.</i>	Limits of read value		Limits of rescaled value	
	Min	Max	Min	Max
<i>r.Pro.</i> Read Process	<i>LL.U.1</i> Lower Limit Variable 1	<i>u.L.U.1</i> Upper Limit Variable 1	<i>LL.r.1</i> Lower Limit Input 1	<i>u.L.r.1</i> Upper Limit Input 1

8.4.c Master reading mode CT 2000.35.014

To enable this operation, *En.ct* should be set on the parameter 160 *nb.PA*. If you connect the current transformer to the serial port, you may read the RMS current absorbed by the load and show it on display 2 by setting *RMS.cu.* on the parameter 123 *u.i.d.2*.

8.4.d Master reading mode CT 2000.35.014 as amperometer

To enable this operation, *En.c.t.R.* should be set on the parameter 160 Пб.ПР.

If you connect the current transformer to the serial port, the RMS current measured will be the process of the ATR144: by means of this mode the device will become an ammeter.

9 Reading and configuration through NFC

	Android®	iOS®
Scan the Qr-Code to download the App on Google Play Store:		

ATR144 is supported by the App MyPixsys: using an ANDROID smartphone with NFC connection it is possible to program the device without using a dedicated equipment*.

*With iOS App, communication between the smartphone and the device is through the RFID Programmer > Bluetooth (2000.35.099), which must be placed on the device's NFC connection point.

MyPixsys allows to read and view data already on the device, modify its parameters and setpoints, save and send (via email) complete configurations, reload backups and factory settings.

Procedure:

- Make sure that the NFC sensor of the Android® phone is enabled and that there are no metallic materials between the smartphone and the device (e.g., aluminum covers or magnetic stands);
- Place the NFC antenna of the smartphone / RFID Programmer > Bluetooth at the antenna of the device (located on the front);
- Enable system sounds on your phone, as the notification

sound confirms that the device has correctly been detected

The App interface is provided with four tabs: SCAN, DATA, WRITE, EXTRA.

Select the first tab "SCAN" to read data stored into the internal memory of the device; place the smartphone in contact with its frontal panel, making sure that the phone's antenna matched with that of the device.

Once detected the device, the App emits a notification sounds and proceeds with the model identification and the reading of the parameters.

The graphic interface shows the advancement and switches to the second tab "DATA". It is now possible to move the smartphone away from the controller to make the required modifications more easily.

The device parameters are divided into collapsible groups and are displayed with name, current value and reference index to the manual.

Click on a row to open the setting screen of the related parameter with the detailed view of available options (in case of multiple choice parameters) or of the minimum/maximum/decimals limits (for numeric parameters). Once selected the chosen value, the related row will be updated and underlined into the tab "DATA" (hold down the line to undo changes).

To download the new configuration on your device, select the third tab "WRITE", place again the smartphone in contact with the device and wait for the operation to complete. The device will show a restart request, necessary to update the configuration with the new written modifications; if it does not restart, the STR581 will continue to work with the previous configuration.

In addition to the classic operation of parameters reading->-modification->writing, MyPixsys is provided with additional functions which can be accessed by the tab "EXTRA", as save/upload and email the entire configuration and restore factory values.

9.1 Config. through memory card

The device can be configured through a memory card (2100.30.013). This one is linked to the micro-USB port on the upper side of the device.

9.2 Creation / update memory card



In order to save a parameter configuration in the memory card, connect it to micro-USB port and power the instrument. If the memory has never been configured, the device starts normally, but if its data are considered valid, it is possible to view on the display **MEMO SKIP**. Press **SET** in order to start the product without uploading any data from the memory card. Configure, set the parameters and exit configuration. Now, the device saves the configuration just created also in the memory.

9.3 Loading config. from memory card



In order to charge a configuration previously created and saved in the memory card, connect it to the micro-USB port and power the instrument. Now, if the memory is detected and its data are considered valid, it is possible to view on the display **MEMO SKIP**. By pressing **▲** you see **MEMO Load** and with **SET** you confirm the uploading of parameters from the memory card to the controller. If you press directly **SET**, when viewing **MEMO SKIP**, the product starts without uploading any data from the memory card.

10 Loading default values

This procedure allows to restore factory settings of the device.

	Press	Display	Do
1	FNC for 3 sec	Display 1 shows <i>PASS.</i> , while display 2 shows 0000 with the 1st digit flashing.	
2	▲ or ▼	Modify the flashing digit and move to the next one pressing SET .	Enter password 9999.
3	FNC to confirm	The device loads default settings and restarts.	

11 Access configuration

	Press	Display	Do
1	FNC for 3 sec.	Display 1 shows <i>PASS.</i> , while display 2 shows 0000 with the 1st digit flashing.	
2	◆	Modify flashing digit and move to next digit with SET .	Enter password 1234.
3	FNC to confirm	Display 1 shows the first parameters group, display 2 shows the description.	
4	▲ or ▼	Scroll parameters groups.	
5	SET to confirm	Display 1 shows the first parameter of the group and display 2 shows its value.	Press FNC to exit configuration.
6	▲ or ▼	Scroll parameters.	

	Press	Display	Do
7	SET to confirm	Allows parameter modification (display 2 flashes)	
8	▲ or ▼	Increases or decreases visualized value	Introduce new data
9	SET	Confirms and stores the new value.	
10	FNC	Backs to parameter groups selection (see point 3).	Press again FNC to exit configuration

11.1 Parameters list functioning

The controller ATR144 integrates many features that make the configuration parameters list very long. To make it more functional, the parameters list is dynamics and it changes as the user enables / disables the functions. Practically, using a specific function that occupies a given input (or output), the parameters referred to other functions of that resource are hidden to the user making the parameters list more concise. To simplify the reading/interpretation of the parameters, pressing **SET** it is possible to visualize a brief description of the selected parameter.

Finally, keeping pressed **FNC**, it is possible to move from the mnemonic visualization of the parameter to the numeric one, and vice versa. Ex. The first parameter can be displayed as *SEn.l* (mnemonic visualization) or as *P.001* (numeric visualization)

Table of Configuration Parameters

GROUP A - A.in.1 - Analogue input 1

1	SEn.1	Sensor AI1	
		Analogue input configuration / sensor AI1 selection	
	tc. 1	Tc-K (Default)	-260° C..1360° C.
	tc. 5	Tc-S	-40° C..1760° C
	tc. R	Tc-R	-40° C..1760° C
	tc. J	Tc-J	-200° C..1200° C
	tc. t	Tc-T	-260° C..400° C
	tc. E	Tc-E	-260° C..980° C
	tc. N	Tc-N	-260° C..1280° C
	tc. b	Tc-B	100° C..1820° C
	Pt100	Pt100	-200° C..600° C
	Ni100	Ni100	-60° C..180° C
	Ni120	Ni120	-60° C..240° C
	Ntc 1	NTC 10K β 3435K	-40° C..125° C
	Ntc 2	NTC 10K β 3694K	-40° C..150° C
	Ntc 3	NTC 2252 β 3976K	-40° C..150° C
	Ptc	PTC 1K	-50° C..150° C
	Pt500	Pt500	-200° C..600° C
	Pt1k	Pt1000	-200° C..600° C
	PS/d.1	Reserved	
	PS/d.2	Reserved	
	0-1	0..1 V	
	0-5	0..5 V	
	0-10	0..10 V	
	0-20	0..20 mA	
	4-20	4..20 mA	
	0-60	0..60 mV	
	Pot.	Potentiometer (set the value on par. 6)	

- 2** *d.P. 1* **Decimal Point 1**
 Select number of displayed decimal points for AI1
 0 **Default**
 0.0 1 decimal
 0.00 2 decimals
 0.000 3 decimals
- 3** *dEGr.* **Degree**
 °C Celsius degree (**Default**)
 °F Fahrenheit degree
 K Kelvin degree
- 4** *LL. 1* **Lower Linear Input AI1**
 AI1 lower limit only for linear signals. Ex.: with input 4..20 mA this parameter takes value associated to 4 mA. The value may be greater than the one entered on the next parameter.
 Lower limit for termination, in case of process transmission in modbus master.
 -9999..+30000 [digit^{1 p. 101}], **Default: 0.**
- 5** *UL. 1* **Upper Linear Input AI1**
 AI1 upper limit only for linear signals Ex: with input 4..20 mA this parameter takes value associated to 20 mA. The value may be lower than the one entered on the previous parameter.
 Upper limit for termination, in case of process transmission in modbus master.
 -9999..+30000 [digit^{1 p. 101}] **Default:1000**
- 6** *P.A. 1* **Potentiometer Value AI1**
 Selects the value of the potentiometer connected on AI1
 1..150 kohm. **Default: 10kohm**

- 7** *i.o.L.1* **Linear Input over Limits AI1**
 If AI1 is a linear input, allows the process to bypass the limits (Par. 4 and 5).
d.SRb. Disabled (**Default**)
ENRb. Enabled
- 8** *o.cR.1* **Offset Calibration AI1**
 AI1 Offset calibration. Value added/subtracted to the process value (ex: usually correcting the ambient temperature value).
 -9999..+9999 [digit^{1p.101}] (degrees.tenths for temperature sensors). **Default** 0.
- 9** *G.cR.1* **Gain Calibration AI1**
 Value multiplied to the process value to calibrate the working point. Ex: to correct the range from 0..1000°C showing 0..1010°C, set the parameter to -1.0 -100.0%..+100.0%, **Default**: 0.0.
- 10** *Lt.c.1* **Latch-On AI1**
 Automatic setting of limits for AI1 linear input.
d.SRb. Disabled. (**Default**)
STNRd Standard
V.0.Sto. Virtual Zero Stored
V.0.t.oN. Virtual Zero at start
- 11** *c.FL.1* **Conversion Filter AI1**
 ADC Filter: Number of sensor readings to calculate mean that defines process value. **NB**: when readings increase, control loop speed slows down.
 1..15., **Default**: 10

12 *c.Fr.1* Conversion Frequency A11

Sampling frequency of digital / analogue converter for A11. Increasing the conversion speed will slow down reading stability (example: for fast transients, as the pressure, it is advisable to increase sampling frequency)

4.17.HZ	4.17 Hz (Min. conversion speed)
6.25HZ	6.25 Hz
8.33HZ	8.33 Hz
10.0HZ	10.0 Hz
12.5HZ	12.5 Hz
16.7HZ	16.7 Hz (Default) Ideal for filtering noises
	50/60 Hz
19.6HZ	19.6 Hz
33.2HZ	33.2 Hz
39.0HZ	39.0 Hz
50.0HZ	50.0 Hz
62.0HZ	62.0 Hz
123HZ	123 Hz
242HZ	242 Hz
470HZ	470 Hz (Max. speed conversion)

13 *L.c.E.1* Lower Current Error 1

If A11 is a 4-20 mA input, it determines the current value below the probe error E-05 is signaled.

2.0 mA	3.0 mA	(Default)
2.2 mA	3.2 mA	
2.4 mA	3.4 mA	
2.6 mA	3.6 mA	
2.8 mA	3.8 mA	

14÷17 Reserved Parameters - Group A

Reserved parameters - Group A

GROUP B - *cnd.1* - Outputs and regulation Process 1

18 *c.o.u.1* Command Output 1

Selects the command output related to the process1 and the outputs related to the alarms.

- c. o2* Command on relay output Q2.
- c. o1* Command on relay output Q1. (**Default**)
- c. SSR* Command on digital output.
- c. VRL* Servo-valve command with open loop.

ATR144-AD	Command	AL. 1	AL. 2
<i>c. o2</i>	Q2	Q1	DO1
<i>c. o1</i>	Q1	Q2	DO1
<i>c. SSR</i>	DO1	Q1	Q2
<i>c. VRL</i>	Q1(open) Q2(close)	DO1	-

ATR144-AD-T	Command	AL. 1
<i>c. o1</i>	Q1	DO1
<i>c. SSR</i>	DO1	Q1
<i>c. VRL</i>	Q1(open) DO1(close)	-

19 *Ac.t.1* Action type 1

Action type to control process 1.

- HEAT* Heating (N.A.) (**Default**)
- cool* Cooling (N.C.)

20 *c.HY.1* Command Hysteresis 1

Sets the hysteresis value used for process control during ON/OFF functioning

-9999..+9999 [digit^{1 p. 101}] (degrees.tenths for temperature sensors), **Default**: 0.2.

21 *LLS.1* Lower Limit Setpoint 1

Lower limit setpoint selectable for command setpoint 1.
-9999..+30000 [digit^{1 p. 101}] (degrees.tenths for temperature sensors), **Default**: 0.

22 *u.l.S.1* **Upper Limit Setpoint 1**
Lower limit setpoint selectable for command setpoint 1.
-9999..+30000 [digit^{1 p. 101}] (degrees for temperature
sensors), **Default:** 1750.

23 *c.r.E.1* **Command Reset 1**
Type of reset for command contact 1 (always automatic
in P.I.D. functioning)
R.RES. Automatic Reset (**Default**)
M.RES. Manual Reset (by keyboard or by digital
input).
M.RES.S. Manual Reset Stored (keeps relay status
also after an eventual power failure).
R.RES.E. Automatic reset with timed activation.
The command remains active for the time
set on the parameter *c.de.1.*, even if the
conditions generating it are missing. To
be able to act again, the conditions for
activating the command must disappear.

24 *c.S.E.1* **Command State Error 1**
State of contact for command 1 output in case of error.
If Par. 18 *c.O.U.1* (command output 1) is relay or valve:
oPEN Contact or valve open. **Default**
cLoSE Contact or valve closed.
If Par. 18 *c.O.U.1* is digital output (SSR):
oFF Digital output OFF. **Default**
oN Digital output ON.

25 *c.L.d.1* **Command Led 1**
Defines led C1 state corresponding to the related
output. If the valve command is selected, this
parameter is not managed.
o.c. ON with open contact or SSR switched off.
c.c. ON with closed contact or SSR switched
on. (**Default**)

- 26** *c.dE.1* **Command Delay 1**
 Command 1 delay (only in ON / OFF functioning).
 -60:00..60:00 mm:ss. **Default:** 00:00.
 Negative: delay when turning off output.
 Positive: delay when turning on output.
- 27** *c.S.P.1* **Command Setpoint Protection 1**
 Controls access to the command setpoint 1 value
FREE Modification allowed (**Default**)
LOCK Protected
HIDE Protected and not displayed
- 28** *vA.t.1* **Valve Time 1**
 Valve time related to command 1 (declared by the
 manufacturer of the valve)
 1...300 seconds. **Default:** 60.
- 29** *A.M.R.1* **Automatic / Manual 1**
 Enables the automatic/manual selection for command
 1
d.SRB. Disabled (**Default**)
ENRB. Enabled
EN.SEO. Enabled with memory
- 30** *in i.S.* **Initial State**
 Choose the state of the controller when turning it
 on. This only works on the version ATR144-AD-T or
 by enabling the Start/Stop from digital input or SET
 button.
START Start (**Default**)
STOP Stop
STORE. Stored. State of Start/Stop prior to
 switching off.

31	<i>S.v.RS.</i>	State Valve Saturation
		Select the valve status when the output percentage is 100%
	<i>PERC.</i>	The valve opening relay is activated for a time equal to 5% of the valve time (Default)
	<i>F1 %Ed</i>	The valve opening relay is always active

32÷35 Reserved Parameters - Group B

Reserved parameters - Gruppo B

GROUP C - *rEG.1* - Autotuning and PID 1

36	<i>tun.1</i>	Tune 1
		Selects autotuning type for command 1.
	<i>dISAb.</i>	Disabled. If proportional band and integral time parameters are to set to zero, the regulation is ON/OFF type.. (Default)
	<i>Auto</i>	Automatic (Automatic P.I.D. parameters calculation)
	<i>MANU.</i>	Manual (launch by keyboards or by digital input)
	<i>oNcE</i>	Once (P.I.D. parameters calculation only at first start)
	<i>SYNcH.</i>	Synchronized (Autotuning managed by serial)

37	<i>S.d.t.1</i>	Setpoint Deviation Tune 1
		Selects deviation from command setpoint 1 as threshold used by autotuning to calculate P.I.D. parameters.
		0-10000 [digit ^{1 p. 10¹}] (degrees.tenths for temp. sensors).
		Default: 30.0.

- 38** *P.b. 1* **Proportional Band 1**
 Proportional band or process 1 P.I.D. regulation (Process inertia).
 0 ON / OFF if Par.39 *i.t. 1* equal to 0 (**Default**)
 1..10000 [digit^{1 p. 101}] (degrees.tenths for temp. sensors).
- 39** *i.t. 1* **Integral Time 1**
 Integral time for process P.I.D. regulation (Process inertia duration).
 0.0...2000.0 sec. (0.0 = integral disabled), **Default: 0.0**
- 40** *d.t. 1* **Derivative Time 1**
 Derivative time for process P.I.D. regulation (Normally ¼ of integral time).
 0.0...1000.0 sec. (0.0 = derivative disabled), **Default: 0**
- 41** *d.b. 1* **Dead Band 1**
 Dead band of process 1 P.I.D.
 0..10000 [digit^{1 p. 101}] (degrees.tenths for temp. sensors),
Default: 0
- 42** *P.b.c.1* **Proportional Band Centered 1**
 Defines if the proportional band must be centered or not on the setpoint. In double loop functioning (heating/cooling), always disabled.
d,5Rb. Disabled. Band under (heating) or over (cooling)(**Default**)
ENRb. Centered band
- 43** *o.o.S.1* **Off Over Setpoint 1**
 In P.I.D. enables the command output switching off, when a certain threshold is exceeded (setpoint + Par. 44)
d,5Rb. Disabled (**Default**)
ENRb. Enabled

- 44** *o.d.t.1* **Off Deviation Threshold 1**
 Sets deviation from command setpoint, used to calculate the intervention threshold for "Off Over Setpoint 1" function.
 -9999..+9999 [digit^{1 p. 101}] (degrees.tenths for temp. sensors), **Default:** 0
- 45** *c.t. 1* **Cycle Time 1**
 Cycle time for P.I.D. regulation of process 1 (for P.I.D. on remote control switch 15 s; for PID on SSR 2s). For valve refer to parameter 28 *uA.t.1*
 1-300 seconds, **Default:** 15 sec.
- 46** *coF.1* **Cooling Fluid 1**
 Type of refrigerant fluid for heating/cooling P.I.D. for process. Enable the cooling output on parameter AL.1 or AL.2.
- | | |
|--------------|------------------------|
| <i>Air</i> | Air (Default) |
| <i>oil</i> | Oil |
| <i>WATER</i> | Water |
- 47** *P.b.1.1* **Proportional Band Multiplier 1**
 Proportional band multiplier for heating/cooling P.I.D. for process 1. Proportional band for cooling action is given by parameter *P.b. 1* multiplied for this value
 1.00...5.00, **Default:** 1.00
- 48** *o.d.b.1* **Overlap / Dead Band 1**
 Dead band combination for heating / cooling P.I.D. (double action) for process 1.
 Negative: Dead band.
 Positive: overlap.
 -20.0%...50.0%, **Default:** 0.0%

- 49** *c.c.t.1* **Cooling Cycle Time 1**
Cycle time for cooling output in heating/cooling P.I.D. mode for process.
1-300 seconds, **Default:** 10 sec.
- 50** *l.l.p.1* **Lower Limit Output Percentage 1**
Selects min. value for command output percentage.
0%...100%, **Default:** 0%.
- 51** *u.l.p.1* **Upper Limit Output Percentage 1**
Selects max. value for command output percentage.
0%...100%, **Default:** 100%.
- 52** *max.g.t.1* **Max Gap Tune 1**
Sets the max. process-setpoint allowed gap before the automatic tune recalculates PID par. of the process.
0-10000 [digit^{1 p. 10¹}] (degrees.tenths for temp. sensors),
Default: 2.0
- 53** *min.p.1* **Minimum Proportional Band 1**
Selects the min. proportional band 1 value selectable by the automatic tune for the PID regulation of process.
0-10000 [digit^{1 p. 10¹}] (degrees.tenths for temp. sensors),
Default: 3.0
- 54** *max.p.1* **Maximum Proportional Band 1**
Selects the max. proportional band 1 value selectable by the automatic tune for the PID regulation of process.
0-10000 [digit^{1 p. 10¹}] (degrees.tenths for temp. sensors),
Default: 80.0
- 55** *min.i.1* **Minimum Integral Time 1**
Selects the min. integral time 1 value selectable by the automatic tune for the P.I.D. regulation of process.
0.0...1000.0 seconds, **Default:** 30.0 sec.

56 *o.c.L.1* Overshoot Control Level 1

The overshoot control function prevents said event from happening during startup or upon modification of the setpoint. Setting this value too low could cause the overshoot to not be fully absorbed, while higher values might increase the time needed to reach the setpoint.

disAb.

LEV.1

...

LEV.5 (Default)

...

LEV.10

57÷61 Reserved Parameters - Group C

Reserved parameters - Group C.

GROUP D - AL. 1 - Alarm 1

62 AL.1.F. Alarm 1 Function

Alarm 1 selection.

<i>d.SRb.</i>	Disabled (Default)
<i>Rb.uP.R.</i>	Absolute Upper Activation. Absolute referred to the process, active over
<i>Rb.Lo.R.</i>	Absolute Lower Activation. Absolute referred to the process, active under
<i>bANd</i>	Band alarm (command setpoint \pm alarm setpoint)
<i>R.bANd</i>	Asymmetric band alarm (command setpoint + alarm setpoint 1 H and command setpoint - alarm setpoint 1 L).
<i>uP.dEV.</i>	Upper Deviation alarm
<i>Lo.dEV.</i>	Lower Deviation alarm
<i>Rb.c.u.R.</i>	Absolute Command Upper Activation. Absolute alarm referred to the command setpoint, active over
<i>Rb.c.L.R.</i>	Absolute Command Lower Activation. Absolute alarm referred to the command setpoint, active under
<i>RuN</i>	Status alarm (active in RUN/START)
<i>cool</i>	Cold actuator auxiliary (Cold action in double loop)
<i>c.Ru*</i>	Auxiliary for job distribution on the command output. It cyclically replaces the command output for the time set on the parameter <i>R.l.dE</i> . If <i>R.l.dE</i> = 0, it is activated parallel to the command output. It does not work in case of valve control.
<i>PRb.EP.</i>	Probe error. Alarm active in case of sensor rupture.
<i>L.b.R.</i>	Loop Break Alarm (see paragraph 7.8)
<i>tMR.1</i>	Related to timer 1 (see par. 186 <i>tPr.1</i>)
<i>tMR.2</i>	Related to timer 2 (see par. 189 <i>tPr.2</i>)
<i>tMR.1.2</i>	Related to both timers
<i>d.i. 1</i>	Digital Input 1. Active when digital input 1

	is active.
<i>d.i. 2</i>	Digital Input 2. Active when digital input 2 is active.
<i>REM.</i>	Remote. The alarm is enabled by the word 1220
<i>P.Ru*</i>	Auxiliary 1 for cycle (programmer vers. only)

63 *Al.S.o.* Alarm 1 State Output

Alarm 1 output contact and intervention type.

<i>N.o. 5t.</i>	(N.O. Start) Normally open, active at start (Default)
<i>N.c. 5t.</i>	(N.C. Start) Normally closed, active at start
<i>N.o. tH.</i>	(N.O. Threshold) Normally open, active on reaching alarm ^{2p.101}
<i>N.c. tH.</i>	(N.C. Threshold) Normally closed, active on reaching alarm ^{2p.101}
<i>N.o.tH.v.</i>	(N.O. Threshold Variation) disabled after changing control setpoint ^{3p.101}
<i>N.c.tH.v.</i>	(N.C. Threshold Variation) disabled after changing control setpoint ^{3p.101}

64 *Al.HY.* Alarm 1 Hysteresis

Alarm 1 hysteresis

-9999..+9999 [digit^{1 p. 101}] (degrees.tenths for temp. sensors). **Default** 0.5.

65 *Al.LL.* Alarm 1 Lower Limit

Lower limit selectable for the alarm 1 setpoint.

-9999..+30000 [digit^{1 p. 101}] (degrees.tenths for temp. sensors). **Default** 0.

66 *Al.U.L.* Alarm 1 Upper Limit

Upper limit selectable for the alarm 1 setpoint

-9999..+30000 [digit^{1 p. 101}] (degrees.tenths for temp. sensors). **Default** 1750.

67	<i>R.L.R.E.</i>	Alarm 1 Reset
		Alarm 1 contact reset type (always autom. if <i>R.L.I.F.</i> = <i>c.</i> <i>R.U.H.</i>).
	<i>R.RES.</i>	Automatic reset (Default)
	<i>M.RES.</i>	Manual reset (manual reset by SET key or by digital input)
	<i>M.RES.S.</i>	Stored manual reset (keeps the output status also after a power failure)
	<i>R.RES.t.</i>	Automatic reset with timed activation. The alarm remains active for the time set on the parameter <i>R.t.d.E.</i> , even if the conditions generating it are missing. To be able to act again, the alarm conditions must disappear.

68	<i>R.I.S.E.</i>	Alarm 1 State Error
		Alarm 1 output status in case of error.
		If the alarm output is a relay:
	<i>oPEN</i>	Contact or valve open. (Default)
	<i>cLoSE</i>	Contact or valve closed.
		If the alarm output is digital output (SSR):
	<i>oFF</i>	Digital output OFF. (Default)
	<i>oN</i>	Digital output ON.

69	<i>R.I.L.d.</i>	Alarm 1 Led
		Defines the status of the led A1 in correspondence of the related output
	<i>o.c.</i>	ON with open contact or DO switched off.
	<i>c.c.</i>	ON with closed contact or DO switched on. (Default)

70 *AL1DE* Alarm 1 Delay

Alarm 1 Delay.

-60:00..60:00 mm:ss (hh:mm if AL.1.F. = c.RU*),

Default: 00:00.

Negative value: delay when leaving alarm status

Positive value: delay when triggering alarm status.

71 *AL1SP* Alarm 1 Setpoint Protection

Controls access to the alarm 1 setpoint

FREE Editable by the user (**Default**)

LOCK Protected

HIDE Protected and hidden

72 *AL1LB* Alarm 1 Label

Selects the message displayed in case of alarm 1 intervention.

DISAB. Disabled (**Default**)

Lb. 01 Message 1 (see table on paragraph 13.1)

Lb. 16 Message 16 (see table on paragraph 13.1)

USER.L. Custom message (modifiable by the user through the app or via modbus)

73÷77 Reserved Parameters - Group D

Reserved parameters - Group D.

GROUP E - AL. 2 - Alarm 2

78 AL.2.F. Alarm 2 Function

Alarm 2 selection.

<i>d.SRb.</i>	Disabled (Default)
<i>Rb.uP.R.</i>	Absolute Upper Activation. Absolute referred to the process, active over
<i>Rb.Lo.R.</i>	Absolute Lower Activation. Absolute referred to the process, active under
<i>bANd</i>	Band alarm (command setpoint \pm alarm setpoint)
<i>R.bANd</i>	Asymmetric band alarm (command setpoint + alarm setpoint 2 H and command setpoint - alarm setpoint 2 L).
<i>uP.dEV.</i>	Upper Deviation alarm
<i>Lo.dEV.</i>	Lower Deviation alarm
<i>Rb.c.u.R.</i>	Absolute Command Upper Activation. Absolute alarm referred to the command setpoint, active over
<i>Rb.c.L.R.</i>	Absolute Command Lower Activation. Absolute alarm referred to the command setpoint, active under
<i>RuN</i>	Status alarm (active in RUN/START)
<i>cool</i>	Cold actuator auxiliary (Cold action in double loop)
<i>c.Ru*</i>	Auxiliary for job distribution on the command output. It cyclically replaces the command output for the time set on the parameter <i>R.2.dE</i> . If <i>R.2.dE</i> = 0, it is activated parallel to the command output. It does not work in case of valve control.
<i>PRb.EP.</i>	Probe error. Alarm active in case of sensor rupture.
<i>L.b.R.</i>	Loop Break Alarm. (see paragraph 7.8)
<i>tMR.1</i>	Related to timer 1 (see par. 186 <i>tPr.1</i>)
<i>tMR.2</i>	Related to timer 2 (see par. 189 <i>tPr.2</i>)
<i>tMR.1.2</i>	Related to both timers
<i>d.i. 1</i>	Digital Input 1. Active when digital input 1

	is active.
<i>d.i. 2</i>	Digital Input 2. Active when digital input 2 is active.
<i>REM.</i>	Remote. The alarm is enabled by the word 1221
<i>P.Ru^x</i>	Auxiliary 2 for cycle (programmer version only)

79 *A2S.o.* Alarm 2 State Output

Alarm 2 output contact and intervention type.

<i>N.o. 5t.</i>	(N.O. Start) Normally open, active at start (Default)
<i>N.c. 5t.</i>	(N.C. Start) Normally closed, active at start
<i>N.o. tH.</i>	(N.O. Threshold) Normally open, active on reaching alarm ^{2p.101}
<i>N.c. tH.</i>	(N.C. Threshold) Normally closed, active on reaching alarm ^{2p.101}
<i>N.o.tH.v.</i>	(N.O. Threshold Variation) disabled after changing control setpoint ^{3p.101}
<i>N.c.tH.v.</i>	(N.C. Threshold Variation) disabled after changing control setpoint ^{3p.101}

80 *A2HY.* Alarm 2 Hysteresis

Alarm 2 hysteresis

-9999..+9999 [digit^{1 p. 101}] (degrees.tenths for temp. sensors), **Default:** 0.5.

81 *A2LL.* Alarm 2 Lower Limit

Lower limit selectable for the alarm 2 setpoint.

-9999..+30000 [digit^{1 p. 101}] (degrees.tenths for temp. sensors), **Default:** 0.

- 82** *AL2UL* **Alarm 2 Upper Limit**
Upper limit selectable for the alarm 2 setpoint.
-9999..+30000 [digit^{1 p. 101}] (degrees.tenths for temp. sensors), **Default:** 1750.
- 83** *AL2rE* **Alarm 2 Reset**
Alarm 2 contact reset type (always automatic if *AL2RF* = c. *ALUH*).
R.RES. Automatic reset (**Default**)
M.RES. Manual reset (manual reset by SET key or by digital input)
M.RES.S. Stored manual reset (keeps the output status also after a power failure)
R.RES.t. Automatic reset with timed activation. The alarm remains active for the time set on the parameter *AL2dE*, even if the conditions generating it are missing. To be able to act again, the alarm conditions must disappear.
- 84** *AL2SE* **Alarm 2 State Error**
Alarm 2 output status in case of error.
If the alarm output is relay
aPEN Contact or open valve (**Default**)
cLoSE Contact or closed valve.
If the alarm output is digital (SSR):
aFF Digital output OFF (**Default**)
aH Digital output ON.
- 85** *AL2Ld* **Alarm 2 Led**
Defines the status of the led A2 in correspondence of the related output.
a.c. ON with open contact or DO switched off.
c.c. ON with closed contact or DO switched on. (**Default**)

86 *AL2DE* Alarm 2 Delay

Alarm 2 Delay.

-60:00..60:00 mm:ss (hh:mm if AL.2.F. = c.AL2*),

Default: 0.

Negative value: delay when exit alarm status.

Positive value: delay when enter alarm status

87 *AL2SP* Alarm 2 Setpoint Protection

Allows or not to change the alarm 2 setpoint

FREE Editable by the user (**Default**)

LOCK Protected

HIDE Protected and not visualized

88 *AL2LB* Alarm 2 Label

Selects the message to be visualized in case of alarm 2 intervention

DISAB. Disabled (**Default**).

Lb. 01 Message 1 (see table on paragraph 13.1)

..

Lb. 16 Message 16 (see table on paragraph 13.1)

USER.L. Message personalized (modifiable by the user through the app or via modbus)

89÷93 Reserved Parameters - Group E

Reserved parameters - Group E.

GROUP F - d.i. 1 - Digital input 1

94 d.i.1.F. Digital Input 1 Function

	Digital input 1 functioning.
d.SRb.	Disabled (Default)
2t.SW.	2 Setpoints Switch
2t.SW.i.	2 Setpoints Switch Impulsive
3t.SW.i.	3 Setpoints Switch Impulsive
4t.SW.i.	4 Setpoints Switch Impulsive
St./St.	Start / Stop. Status of the controller, upon power-up, depends on parameter 30 in 1.5.
RUN	Run. With the controller in STOP the alarms remain active.
Ext.AL.	External alarm. The controller goes on STOP and the alarms will be disabled. The controller does not return to START automatically: for this operation, the user's intervention is required.
Hold	Lock conversion (stop all conversions and display values)
TUNE	Enable / disable tuning if the parameter 36 Tun.1 is set on PAR.1 .
RM.MA.i.	Automatic / Manual Impulse (if enabled on parameter 29 RM.MA.1)
RM.MA.c.	Automatic / Manual Contact (if enabled on parameter 29 RM.MA.1)
Act.ty.	Action Type. Cooling regulat. if D.I. is active, otherwise heating reg.
A.i. 0	Analogue Input 0. Set AI to zero
M. RES.	Manual reset. Reset the outputs if selected as manual reset.
t.1.RUN	Timer 1 run. The timer 1 runs while D.I. is activated
t.1. S.E.	Timer 1 Start End. D.I. starts and stops the timer 1(impulsive)
t.1.StR.	Timer 1 Start. D.I. starts the timer 1(impulsive)

<i>t.1.END</i>	Timer 1 End. D.I. stops the timer 1(impulsive)
<i>t.2.RUN</i>	Timer 2 run. The timer 2 counts with D.I. activated
<i>t.2. S.E.</i>	Timer 2 Start End. D.I. starts and stops the timer 2(impulsive)
<i>t.2.STR.</i>	Timer 2 Start. D.I. starts the timer 2(impulsive)
<i>t.2.END</i>	Timer 2 End. D.I. stops the timer 2(impulsive)
<i>Lo.cFG.</i>	Lock configuration and setpoints.
<i>uP.KEY</i>	Simulates the functioning of UP key.
<i>down.k.</i>	Simulates the functioning of DOWN key.
<i>Fnc. k.</i>	Simulates the functioning of FNC key.
<i>SET. k.</i>	Simulates the functioning of SET key (password entry excluded).

95 *d.i.c.* **Digital Input 1 Contact**

Defines the resting contact of the digital input 1.

N.oPEN Normally open (**Default**)

N.cLoS. Normally closed

96÷100 **Reserved Parameters - Group F**

Reserved parameters - Group F.

GROUP G - d.i. 2 - Digital input 2

101 d.i.2.F. Digital Input 2 Function

	Digital input 2 functioning.
d.SRb.	Disabled (Default)
2t. SW.	2 Setpoints Switch
2t.SW.i.	2 Setpoints Switch Impulsive
3t.SW.i.	3 Setpoints Switch Impulsive
4t.SW.i.	4 Setpoints Switch Impulsive
5t./5t.	Start / Stop.
	Status of the controller, upon power-up, depends on parameter 30 in 1.5.
RUN	With the controller in STOP the alarms remain active.
Ext.AL.	External alarm. The controller goes on STOP and the alarms will be disabled. The controller does not return to START automatically: for this operation, the user's intervention is required.
Hold	Lock conversion (stop all conversions and display values)
tUNE	Enable / disable tuning if the parameter 36 tUN.1 is set on PAOU.
RU.MA.i.	Automatic / Manual Impulse (if enabled on parameter 29 R.PA.1)
RU.MA.c.	Automatic / Manual Contact (if enabled on parameter 29 R.PA.1)
RcE.tY.	Action Type. Cooling regulation if D.I. is active, otherwise heating reg.
R.i. 0	Analogue Input 0. Set AI to zero
M. RES.	Manual reset. Reset the outputs if selected as manual reset.
t.1.RUN	Timer 1 run. The timer 1 counts with D.I. activated
t.1. S.E.	Timer 1 Start End. D.I. starts and stops the timer 1(impulsive)

<i>t.1.StR.</i>	Timer 1 Start. D.I. starts the timer 1(impulsive)
<i>t.1.END</i>	Timer 1 End. D.I. stops the timer 1(impulsive)
<i>t.2.RuN</i>	Timer 2 run. The timer 2 counts with D.I. activated
<i>t.2. S.E.</i>	Timer 2 Start End. D.I. starts and stops the timer 2 (impulsive)
<i>t.2.StR.</i>	Timer 2 Start. D.I. starts the timer 2 (impulsive)
<i>t.2.END</i>	Timer 2 End. D.I. stops the timer 2(impulsive)
<i>Lo.cFG.</i>	Lock configuration and setpoints
<i>uP.KEY</i>	Simulates the functioning of UP key.
<i>dowN.K.</i>	Simulates the functioning of DOWN key.
<i>Fnc. K.</i>	Simulates the functioning of FNC key.
<i>SEt. K.</i>	Simulates the functioning of SET key (password entry excluded).

102	<i>d.i.2.c.</i>	Digital Input 2 Contact
		Defines the resting contact of the digital input 2.
	<i>N.oPEN</i>	Normally open (Default)
	<i>N.cLoS.</i>	Normally closed

103÷107	Reserved Parameters - Group G
	Reserved parameters - Group G.

GROUP H - 5FE.5 - Soft-start and mini cycle

- 108** *dE.5t.* **Delayed Start**
To set the initial waiting time for the delayed start of the setting or cycle, even in case of a blackout. The elapsed time is saved every 10 minutes.
0 Initial waiting time disabled: the controller starts immediately (**Default**)
00:01-24:00 Initial waiting time enabled (hh:mm)
- 109** *Pr.cY.* **Pre-programmed Cycle**
Enables special functionings.
d,5Rb. Disabled (**Default**)
ENRb. Enabled (all remote setpoint functions are inhibited)
- 110** *SS.tY.* **Soft-Start Type**
Enables and selects the soft-start type
d,5Rb. Disabled (**Default**)
GRPd. Gradient
PERc. Percentage (with only pre-programmed cycle disabled)
- 111** *SS.Gr.* **Soft-Start Gradient**
Rising/falling gradient for soft-start and pre-programmed cycle.
0..20000 [digit/hour^{1 p. 101}] (degrees.tenths/hour for temp. sensors), **Default:** 1000
- 112** *SS.PE.* **Soft-Start Percentage**
Output percentage during soft-start function.
0..100%, **Default:** 50%
- 113** *SS.tH.* **Soft-Start Threshold**
Threshold under which the soft-start percentage function is activated, at starting.
-9999..30000 [digit^{1 p. 101}] (degrees.tenths for temp. sensors), **Default:** 1000

- 114** *SS.t.t.* **Soft-Start Time**
 Max. Softstart duration: if the process will not reach the threshold selected on par. *SS.tH.* within the selected time, the controller starts to regulate on setpoint.
00:00 Disabled
00:01-24:00 hh:mm, **Default:** 00:15
- 115** *MA.t.t.* **Maintenance Time**
 Maintenance time for pre-programmed cycle.
00:00-24:00 hh.mm, **Default:** 00:00
- 116** *FR.Gr.* **Falling Gradient**
 Falling gradient for pre-programmed cycle.
0 Disabled (**Default**)
1..10000 [digit/hour^{1 p. 101}] (degrees.tenths/hour for temp. sensors)
- 117÷121** **Reserved Parameters - Group H**
 Reserved parameters - Group H

GROUP 1 - dISP. - Display and interface

- 122** *uFlt* **Visualization Filter**
dSRb. Disabled
PtCHF Pitchfork filter (**Default**)
F1.oPd. First Order
F1.oRp. First Order with Pitchfork
2 SR.M. 2 Samples Mean
...
10.SR.M. 10 Samples Mean
- 123** *uId2* **Visualization Display 2**
Selects visualization on display 2.
c1.SPv Command 1 setpoint (**Default**)
ou.PE.1 Percentage of command output 1
RMS.cu. RMS current (if the master function CT 2000.35.014 is enabled).
- 124** *tNo.d.* **Timeout Display**
Determines the display timeout
dSRb. Disabled. Display always ON (**Default**)
15 S 15 seconds
1 M.N 1 minute
5 M.N 5 minutes
10M.N 10 minutes
30M.N 30 minutes
1 H 1 hour
- 125** *tNo.S.* **Timeout Selection**
Selects which display is switched off when Display Timeout expires
dSP.1 Display 1
dSP.2 Display 2 (**Default**)
dSP.1.2 Display 1 and 2
d.1.2.Ld. Display 1, 2 and led

126	u.P.P.c.	User Menu Pre-Programmed Cycle
		Allows modification to the rising/falling gradient and retention time from the user menu (during the pre-programmed cycle functioning). To modify the parameters, press SET.
	d.SAb.	Disabled (Default)
	R.S.GP.	Only rising gradient
	MR.t.	Only retention time
	R.G.M.t.	Rising gradient and retention time
	FAL.GP	Only falling gradient
	R.F.G.	Rising and falling gradient
	FR.G.M.t.	Falling gradient and retention time
	R.F.G.M.t.	Rising gradient, retention time and falling gradient

127	ScL.t.	Scrolling Time
		Selects the timeout for the user menu data visualization, before returning to the default page
	3 S	3 seconds
	5 S	5 seconds (Default)
	10 S	10 seconds
	30 S	30 seconds
	1 M.N	1 minutes
	5 M.N	5 minutes
	10 M.N	10 minutes
	MAN.Sc.	Manual scroll

128	d.SP.F.	Display Special Functions
	d.SAb.	Special functions disabled
	SWAP	Shows the setpoint on display 1 and the process on display 2 (only if Par. 123 u.i.d.2 set on c.ISP.u)
	Hi.dE	Hide the process and the command setpoint. When the command output is active, it generate a sequence with the segments on display 1. Turn on 4 dashes (----) when the output is OFF.

129	<i>nFcL.</i>	NFC Lock
		Disables NFC capabilities
	<i>d.5Rb.</i>	NFC lock Disabled: behaviour, the device can be programmed via NFC using the MyPixsys smartphone app. (Default)
	<i>ENRb.</i>	NFC lock Enabled: NFC protection active, the device will ignore any configuration update written through nfc.

130	<i>5.F.5.F.</i>	Set key special functions
		Assign special functions to the SET button. To execute the function the key must be pressed for 1 s.
	<i>d.5Rb.</i>	No special function linked to the SET key. (Default)
	<i>5E./5E.</i>	Start/Stop. Pressing SET key the controller switches from Start to Stop and vice versa. Status of the controller, upon power-up, depends on parameter 30 <i>in r.5.</i>
	<i>2E.5W.</i>	2 Threshold Switch. The controller changes the regulation setpoint alternating between Set1 and Set2
	<i>3E.5W.</i>	3 Threshold Switch. The controller changes the regulation setpoint alternating between Set1, Set2 and Set3
	<i>4E.5W.</i>	4 Threshold Switch. The controller changes the regulation setpoint alternating between Set1, Set2, Set3 and Set4
	<i>R.r. 0</i>	Analogue Input 0. Set the analog input to zero (zero tare)

131÷140 **Reserved Parameters - Group I**
 Reserved parameters - Group I.

GROUP J - Lo.br. - Loop Break

141	L.b. S. d.5Ab. AutoM. MANU.	Loop Break State Loop break disabled. (Default) Loop break enabled with automatically calculated time and band. Loop break enabled with time (par. Lb. t.) And band (par. Lb. b.) entered by the user.
-----	--------------------------------------	---

142	L.b. t.	Loop Break Time Sets the maximum time span allowed for a process variation to occur before the loop break error is triggered. The minimum delta variation considered is set in P_143 (L.b. b) 00:01..99:59 mm:ss, Default: 02:00.
-----	---------	--

143	L.b. b.	Loop Break Band Sets the minimum delta process variation required to occur (within the timeframe set in P_142 Lb. t.) in order to avoid a loop break error 1..+10000 [digit ^{1 p. 101}] (degrees.tenths for temp. sensors), Default: 100.
-----	---------	--

144÷148		Reserved Parameters - Group J Reserved parameters - Group J.
---------	--	--

GROUP K - *S.L.S.P.* - Serial communication Slave

(only for ATR144-xxx-T)

- | | | |
|-----|--|---|
| 149 | <i>Mod.SL</i>
<i>d.SRB.</i>
<i>ENRB.</i> | Modbus Slave
Disabled
Enabled. (Default) |
| 150 | <i>SLAd.</i> | Slave Address
Select slave address for serial communication.
1...254 Default: 247 |
| 151 | <i>SLb.r.</i> | Slave Baud Rate
Selects baudrate for serial communication
1.2 k 1200 bit/s
2.4 k 2400 bit/s
4.8 k 4800 bit/s
9.6 k 9600 bit/s
19.2 k 19200 bit/s (Default)
28.8 k 28800 bit/s
38.4 k 38400 bit/s
57.6 k 57600 bit/s
115.2k 115200 bit/s |
| 152 | <i>S.S.P.F.</i> | Slave Serial Port Format
Selects the format used by the ATR144 during modbus RTU serial communication.
8-N-1 8 bit, no parity, 1 stop bit (Default)
8-E-1 8 bit, even parity, 1 stop bit
8-o-1 8 bit, odd parity, 1 stop bit
8-N-2 8 bit, no parity, 2 stop bit
8-E-2 8 bit, even parity, 2 stop bit
8-o-2 8 bit, odd parity, 2 stop bit |
| 153 | <i>SE.dE.</i> | Serial Delay
Sets the serial delay
0...100 ms, Default: 5 |

154	<i>oFF.L.</i>	Off Line
		Selects the off-line time frame. If there is no serial communication during this period, the controller switches-off the command output
	0	Offline disabled (Default)
	0.1-600.0	tenths of second.

155÷159 **Reserved Parameters - Group K** Reserved parameters - Group K.

GROUP L - *MA.S.P.* – Master Serial Port

		<i>(only for ATR144-xxx-T)</i>
160	<i>MA.MA.</i>	Modbus Master
	<i>d.SAb.</i>	Disabled (Default)
	<i>ENAb.</i>	Enabled.
	<i>EN.ct</i>	Enabled for handling CT 2000.35.014.
	<i>EN.ct.R.</i>	Enabled for handling CT 2000.35.014 as amperometer (the current will be the process).

161	<i>tAd.</i>	Target Address
		Sets the slave address used for serial communication
	0...254	Default: 1

162	<i>MA.b.r.</i>	Master Baud Rate
		Sets the baud rate used for serial communication while the ATR144 is operating in Master mode
	1.2 k	1200 bit/s
	2.4 k	2400 bit/s
	4.8 k	4800 bit/s
	9.6 k	9600 bit/s
	19.2 k	19200 bit/s (Default)
	28.8 k	28800 bit/s
	38.4 k	38400 bit/s
	57.6 k	57600 bit/s
	115.2k	115200 bit/s

- 163** *MS.PF.* **Master Serial Port Format**
 Selects the format used by the ATR144 (when operating in master mode) during modbus RTU serial communication
- | | |
|--------------|---|
| <i>B-N-1</i> | 8 bit, no parity, 1 stop bit (Default) |
| <i>B-E-1</i> | 8 bit, even parity, 1 stop bit |
| <i>B-O-1</i> | 8 bit, odd parity, 1 stop bit |
| <i>B-N-2</i> | 8 bit, no parity, 2 stop bit |
| <i>B-E-2</i> | 8 bit, even parity, 2 stop bit |
| <i>B-O-2</i> | 8 bit, odd parity, 2 stop bit |
- 164** *uAr.1* **Variable 1**
 Selects the variable 1 used by the ATR144 in master mode.
- | | |
|------------------|--|
| ---- | Reserved |
| <i>W.PPO.</i> | Write Process (Default) |
| <i>R.W.C.SE.</i> | Read/write command setpoint |
| <i>W.C.OU.P.</i> | Write command output percentage |
| <i>R.W.A1.S.</i> | Read/Write Alarm 1 setpoint |
| <i>W.CONST.</i> | Write constant |
| <i>R.PPO.</i> | Read Process (remote process from modbus master) |
- 165** *u.l.Ad.* **Variable 1 Address**
 Sets the address used by the master to write/read *uAr.1*
 0...65535 **Default:** 1000
- 166** *LL.u.1* **Lower Limit Variable 1**
 Lower range limit used for rescaling variable 1
 -9999..+30000 [digit^{1 p. 101}] (degrees for temperature sensors), **Default:** 0.

- 167** *u.L.u.1* **Upper Limit Variable 1**
Upper range limit used for rescaling variable 1
-9999..+30000 [digit^{1 p. 101}] (degrees for temperature sensors), **Default:0**
- 168** *con.1* **Constant 1**
Sets the constant value that will be transmitted while operating in master mode, if selected on *uAr.1*
0...65535 **Default: 0**
- 169** *uAr.2* **Variable 2**
Selects the variable 2 used by the ATR144 in master mode.
- | | |
|------------------|---------------------------------|
| <i>d.5Ab.</i> | Disabled (Default) |
| <i>W. PRo.</i> | Write Process |
| <i>R.W.c.SE.</i> | Read/write command setpoint |
| <i>W.c.oU.P.</i> | Write command output percentage |
| <i>R.W.RI.S.</i> | Read/Write Alarm 1 setpoint |
| <i>W.coN5.</i> | Write constant |
- 170** *u.2Ad.* **Variable 2 Address**
Sets the address used by the master to write/read *uAr.2*
0...65535 **Default: 1001**
- 171** *l.L.u.2* **Lower Limit Variable 2**
Lower range limit used for rescaling variable 2
-9999..+30000 [digit^{1 p. 101}] (degrees for temperature sensors), **Default: 0.**
- 172** *u.L.u.2* **Upper Limit Variable 2**
Upper range limit used for rescaling variable 2
-9999..+30000 [digit^{1 p. 101}] (degrees for temperature sensors), **Default:0**

- 173** *con.2* **Constant 2**
Sets the constant value that will be transmitted while operating in master mode, if selected on *uAr.2*.
0...65535 **Default: 0**
- 174** *tr.dE.* **Transmission Delay**
Defines the minimum delay introduced by the modbus master protocol between the full data reception by the slave and a new query.
0...200 ms, **Default: 2**
- 175** *rE.to.* **Reception Timeout**
Defines the maximum wait time (after sending a query to the slave) before reception is canceled due to a timeout.
When this happens, the lost packet counter will be increased.
10...10000 ms, **Default: 100**
- 176** *nuEr.* **Number of Errors**
Defines the maximum number of allowed subsequent faults (reception timeouts, CRC errors) before the slave status is notified as offline.
Any successfull communication will reset the fault counter for off-line management to zero.
Setting this parameter to 0 will prevent the error notification
0...100 **Default: 10**
- 177÷185** **Reserved Parameters - Group L**
Reserved parameters - Group L.

GROUP M - $\epsilon\pi\tau$ - Timer

186 $\epsilon\pi\tau.1$ Timer 1

Enables timer 1

$d.SRb.$ Disabled (**Default**)

$ENRb.$ Enabled

$EN.SEA.$ Enabled and active at start

187 $\epsilon.b.t.1$ Time Base Timer 1

Selects the time base used by timer 1

$MM.SS$ minutes.seconds (**Default**)

$HH.MM$ hours.minutes

188 $A.\epsilon\tau.1$ Action Timer 1

Selects the type of action performed by timer 1 when connected to an alarm

$SEARt$ Active during timer counting (**Default**)

END Active at timer expiry

$WARN.$ Warning. Active 5" before the timer expiry

189 $\epsilon\pi\tau.2$ Timer 2

Enables timer 2

$d.SRb.$ Disabled (**Default**)

$ENRb.$ Enabled

$EN.SEA.$ Enabled and active at start

190 $\epsilon.b.t.2$ Time Base Timer 2

Selects the time base used by timer 2

$MM.SS$ minutes.seconds (**Default**)

$HH.MM$ hours.minutes

191 *А.ТН.2* Action Timer 2

Selects the type of action performed by timer 2 when connected to an alarm

START Active during timer counting (**Default**)

END Active at timer expiry.

WARN. Warning. Active 5" before the timer expiry.

192 *ТН.5.* Timers Sequence

Select the correlation between the two timers.

SINGL. Singles. Timers work independently (**Default**)

SEQUE. Sequential. When timer 1 expires, timer 2 starts.

LOOP Loop. When a timer expires, another one starts.

193÷197 Reserved Parameters - Group M

Reserved parameters - Group M

13 Alarm Intervention Modes

13.a Absolute or threshold alarm active over (par. 62 $R.L.I.F. = R.b.u.P.A.$)

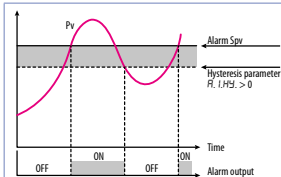

Absolute alarm active over.
Hysteresis value greater than "0" (Par. 64 $R.I.H.Y > 0$).*

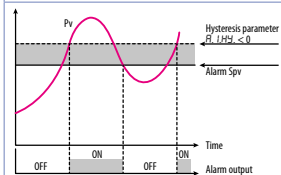

Absolute alarm active over.
Hysteresis value lower than "0" (Par. 64 $R.I.H.Y < 0$).*

13.b Absolute or threshold alarm active below (par. 62 $R.L.I.F. = R.b.L.o.A.$)

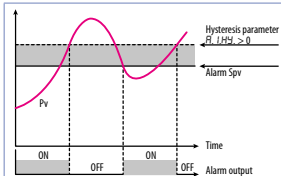

Absolute alarm active below.
Hysteresis value greater than "0" (Par. 64 $R.I.H.Y > 0$).*

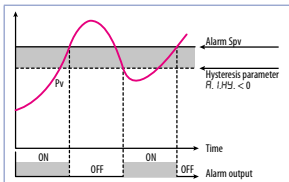

Absolute alarm active below.
Hysteresis value lower than "0" (Par. 64 $R. I.H.Y. < 0$). *

13.c Absolute or threshold alarm referred to command setpoint active over (par. 62 $R.L.I.F. = R.b.c.u.R.$)

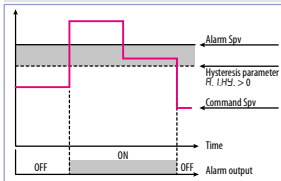

Absolute alarm referred to command setpoint active over.
Hysteresis value greater than "0" (Par. 64 $R. I.H.Y. > 0$). *

13.d Absolute or threshold alarm referred to command setpoint active below (par. 62 $R.L.I.F. = R.b.c.l.R.$)

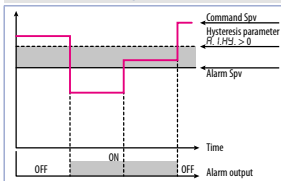

Absolute alarm referred to command setpoint active below.
Hysteresis value greater than "0" (Par. 64 $R. I.H.Y. > 0$). *

13.e Band alarm (par. 62 $R.L.I.F. = bAnd$)

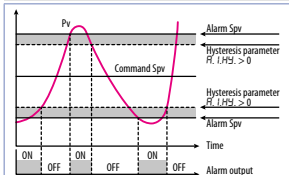

Band alarm hysteresis value greater than "0" (Par. 64 $R.L.I.F. > 0$). *

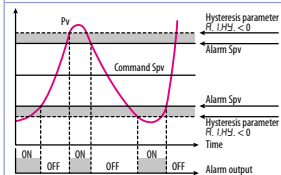

Band alarm hysteresis value lower than "0" (Par. 64 $R.L.I.F. < 0$). *

13.f Asymmetric band alarm (par. 62 $R_{L.I.F.} = R_{bR_{nd}}$)

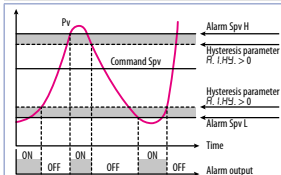

Asymmetric band alarm with hysteresis value greater than "0" (Par. 64 $R_{.I.H.Y.} > 0$). *

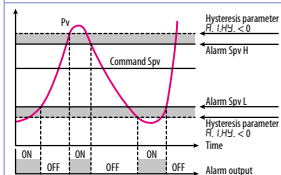

Asymmetric band alarm with hysteresis value lower than "0" (Par. 64 $R_{.I.H.Y.} < 0$). *

* The example refers to alarm 1; the function can also be enabled for alarm 2 on model that include it.

13.g Upper deviation alarm (par. 62 $R_{L.I.F.} = \cup P.dE_{\cup}$)

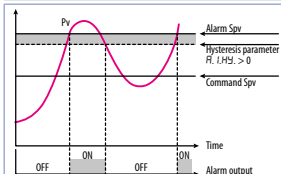

Upper deviation alarm value of alarm setpoint greater than "0" and hysteresis value greater than "0" (Par. 64 $R_{.I.H.Y.} > 0$). **

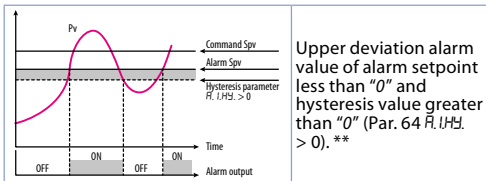

13.h Lower deviation alarm (par. 62 $R.L.I.F. = Lo.dE.U$)

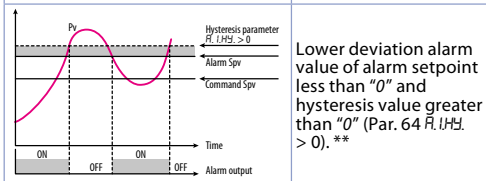
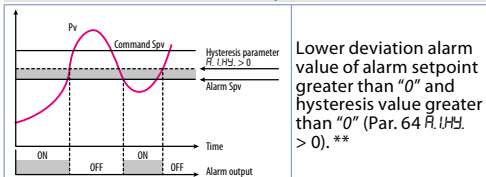

** With hysteresis value less than "0" ($R.I.H.Y. < 0$) the dotted line moves under the alarm setpoint.

13.1 Alarms label

By setting a value from 1 to 16 on the parameters 72 *ALb.* and 88 *ALb.*, the display 2 will show one of the following messages in case of alarm:

Sel.	Message displayed in the alarm event
1	ALARM 1
2	ALARM 2
3	oPEN dOoP
4	cLoSEd dOoP
5	LiGHt oN
6	LiGHt oFF
7	WARnING
8	WARnING

Sel.	Message displayed in the alarm event
9	HiGH LiMiT
10	LoW LiMiT
11	EXtERnAL ALARM
12	tEMPERAtURE ALARM
13	PRESSuRE ALARM
14	FAN cOMMAND
15	cooLiNG
16	oPERAtiNG

In case you set 0, no message will appear. In case the user sets 17, 23 characters will be available to personalize the message using MyPixsys app or modbus.

14 Table of anomaly signals

If installation malfunctions, the controller switches off the regulation output and reports the anomaly noticed. For example, controller will report failure of a connected thermocouple visualizing E-05 (flashing) flashing on display. For other signals see table below.

	Cause	What to do
E-02 SYSTEM Error	Cold junction temperature sensor failure or environment temperature out of range	Call assistance
E-04 EEPROM Error	Incorrect configuration data. Possible loss of instrument calibration	Verify that configuration parameters are correct.
E-05 Probe 1 Error	Sensor connected to AI1 broken or temperature out of range	Control connection with probes and their integrity.
E-07 SERIAL Error	Communication error in modbus master	Check the configuration parameters and the RS485 serial connection
E-08 SYSTEM Error	Missing calibration	Call assistance
E-80 RFID Error	RFID tag malfunction	Call assistance

Notes / Updates

- 1 Display of decimal point depends on setting of parameter SE_n and parameter d.P.*
- 2 On activation, the output is inhibited if the controller is in alarm mode. Activates only if alarm condition reappears, after that it was restored.*
- 3 Changing the control setpoint, the alarm will be disabled. It will stay disabled as long as the parameters that created it are active. It only works with deviation alarms, band alarms and absolute alarms (referring to the control setpoint).*

Table of Configuration Parameters

GROUP A - *A.in.1* - Analogue input 1

1	<i>SEn.1</i>	Sensor AI1	56
2	<i>d.P.1</i>	Decimal Point 1	57
3	<i>dEGr.</i>	Degree	57
4	<i>LL.i.1</i>	Lower Linear Input AI1	57
5	<i>uL.i.1</i>	Upper Linear Input AI1	57
6	<i>P.uA.1</i>	Potentiometer Value AI1	57
7	<i>l.o.L.1</i>	Linear Input over Limits AI1	58
8	<i>o.cA.1</i>	Offset Calibration AI1	58
9	<i>G.cA.1</i>	Gain Calibration AI1	58
10	<i>Lt.c.1</i>	Latch-On AI1	58
11	<i>c.FL.1</i>	Conversion Filter AI1	58
12	<i>c.Fr.1</i>	Conversion Frequency AI1	59
13	<i>L.c.E.1</i>	Lower Current Error 1	59
14÷17		Reserved Parameters - Group A	59

GROUP B - *c.nd.1* - Outputs and regulation Process 1

18	<i>c.ov.1</i>	Command Output 1	60
19	<i>Ac.t.1</i>	Action type 1	60
20	<i>c.Hy.1</i>	Command Hysteresis 1	60
21	<i>LL.S.1</i>	Lower Limit Setpoint 1	60
22	<i>uL.S.1</i>	Upper Limit Setpoint 1	61
23	<i>c.rE.1</i>	Command Reset 1	61
24	<i>c.S.E.1</i>	Command State Error 1	61
25	<i>c.Ld.1</i>	Command Led 1	61
26	<i>c.dE.1</i>	Command Delay 1	62
27	<i>c.S.P.1</i>	Command Setpoint Protection 1	62
28	<i>vA.t.1</i>	Valve Time 1	62
29	<i>A.MA.1</i>	Automatic / Manual 1	62
30	<i>in.i.S.</i>	Initial State	62
31	<i>S.vAS.</i>	State Valve Saturation	63
32÷35		Reserved Parameters - Group B	63

GROUP C - rEG.1 - Autotuning and PID 1

36	tun.1	Tune 1	63
37	S.d.t.1	Setpoint Deviation Tune 1	63
38	P.b. 1	Proportional Band 1	64
39	i.t. 1	Integral Time 1	64
40	d.t. 1	Derivative Time 1	64
41	d.b. 1	Dead Band 1	64
42	P.b.c.1	Proportional Band Centered 1	64
43	o.o.S.1	Off Over Setpoint 1	64
44	o.d.t.1	Off Deviation Threshold 1	65
45	c.t. 1	Cycle Time 1	65
46	co.F.1	Cooling Fluid 1	65
47	P.b.M.1	Proportional Band Multiplier 1	65
48	o.d.b.1	Overlap / Dead Band 1	65
49	c.c.t.1	Cooling Cycle Time 1	66
50	LL.P.1	Lower Limit Output Percentage 1	66
51	uL.P.1	Upper Limit Output Percentage 1	66
52	M.G.t.1	Max Gap Tune 1	66
53	Mn.P.1	Minimum Proportional Band 1	66
54	Mx.P.1	Maximum Proportional Band 1	66
55	Mn.i.1	Minimum Integral Time 1	66
56	o.c.L.1	Overshoot Control Level 1	67
57÷61		Reserved Parameters - Group C	67

GROUP D - AL. 1 - Alarm 1

62	AL.I.F.	Alarm 1 Function	68
63	AL.S.o.	Alarm 1 State Output	69
64	AL.H.Y.	Alarm 1 Hysteresis	69
65	AL.L.L.	Alarm 1 Lower Limit	69
66	AL.u.L.	Alarm 1 Upper Limit	69
67	AL.r.E.	Alarm 1 Reset	70
68	AL.S.E.	Alarm 1 State Error	70
69	AL.L.d.	Alarm 1 Led	70

70	<i>A.1.dE.</i>	Alarm 1 Delay	71
71	<i>A.1.S.P.</i>	Alarm 1 Setpoint Protection	71
72	<i>A.1.L.b.</i>	Alarm 1 Label	71
73÷77		Reserved Parameters - Group D	71
GROUP E - <i>AL. 2</i> - Alarm 2			
78	<i>AL.2.F.</i>	Alarm 2 Function	72
79	<i>A.2.S.o.</i>	Alarm 2 State Output	73
80	<i>A.2.H.Y.</i>	Alarm 2 Hysteresis	73
81	<i>A.2.L.L.</i>	Alarm 2 Lower Limit	73
82	<i>A.2.U.L.</i>	Alarm 2 Upper Limit	74
83	<i>A.2.r.E.</i>	Alarm 2 Reset	74
84	<i>A.2.S.E.</i>	Alarm 2 State Error	74
85	<i>A.2.L.d.</i>	Alarm 2 Led	74
86	<i>A.2.dE.</i>	Alarm 2 Delay	75
87	<i>A.2.S.P.</i>	Alarm 2 Setpoint Protection	75
88	<i>A.2.L.b.</i>	Alarm 2 Label	75
89÷93		Reserved Parameters - Group E	75
GROUP F - <i>d.i. 1</i> - Digital input 1			
94	<i>d.i.1.F.</i>	Digital Input 1 Function	76
95	<i>d.i.1.c.</i>	Digital Input 1 Contact	77
96÷100		Reserved Parameters - Group F	77
GROUP G - <i>d.i. 2</i> - Digital input 2			
101	<i>d.i.2.F.</i>	Digital Input 2 Function	78
102	<i>d.i.2.c.</i>	Digital Input 2 Contact	79
103÷107		Reserved Parameters - Group G	79
GROUP H - <i>S.F.t.S</i> - Soft-start and mini cycle			
108	<i>dE.S.t.</i>	Delayed Start	80
109	<i>Pr.c.Y.</i>	Pre-programmed Cycle	80
110	<i>S.S.t.Y.</i>	Soft-Start Type	80
111	<i>S.S.Gr.</i>	Soft-Start Gradient	80
112	<i>S.S.P.E.</i>	Soft-Start Percentage	80

113	<i>SS.tH.</i>	Soft-Start Threshold	80
114	<i>SS.t.i.</i>	Soft-Start Time	81
115	<i>MA.t.i.</i>	Maintenance Time	81
116	<i>FAGr.</i>	Falling Gradient	81
117÷121		Reserved Parameters - Group H	81
GROUP I - <i>d.i.SP.</i> - Display and interface			
122	<i>v.FLt</i>	Visualization Filter	82
123	<i>v.i.d.2</i>	Visualization Display 2	82
124	<i>t.No.d.</i>	Timeout Display	82
125	<i>t.No.S.</i>	Timeout Selection	82
126	<i>v.NP.c.</i>	User Menu Pre-Programmed Cycle	82
127	<i>ScL.t.</i>	Scrolling Time	83
128	<i>d.SP.F.</i>	Display Special Functions	83
129	<i>nFc.L.</i>	NFC Lock	84
130	<i>S.t.S.F.</i>	Set key special functions	84
131÷140		Reserved Parameters - Group I	84
GROUP J - <i>Lo.br.</i> - Loop Break			
141	<i>L.b. S.</i>	Loop Break State	85
142	<i>L.b. t.</i>	Loop Break Time	85
143	<i>L.b. b.</i>	Loop Break Band	85
144÷148		Reserved Parameters - Group J	85
GROUP K - <i>SL.S.P.</i> - Slave Serial Port (only for ATR144-xxx-T)			
149	<i>nb.SL.</i>	Modbus Slave	86
150	<i>SL.Ad.</i>	Slave Address	86
151	<i>SL.b.r.</i>	Slave Baud Rate	86
152	<i>S.S.P.F.</i>	Slave Serial Port Format	86
153	<i>SE.dE.</i>	Serial Delay	86
154	<i>oFF.L.</i>	Off Line	87
155÷159		Reserved Parameters - Group K	87

GROUP L - *PAR.P.* - Master Serial Port (only for ATR144-xxx-T)

160	<i>Mb.MR.</i>	Modbus Master	87
161	<i>tAd.</i>	Target Address	87
162	<i>Mb.br.</i>	Master Baud Rate	87
163	<i>M.S.P.F.</i>	Master Serial Port Format	88
164	<i>vAr.1</i>	Variable 1	88
165	<i>v.1.Ad.</i>	Variable 1 Address	88
166	<i>LL.v.1</i>	Lower Limit Variable 1	88
167	<i>uL.v.1</i>	Upper Limit Variable 1	89
168	<i>con.1</i>	Constant 1	89
169	<i>vAr.2</i>	Variable 2	89
170	<i>v.2.Ad.</i>	Variable 2 Address	89
171	<i>LL.v.2</i>	Lower Limit Variable 2	89
172	<i>uL.v.2</i>	Upper Limit Variable 2	89
173	<i>con.2</i>	Constant 2	90
174	<i>tr.dE.</i>	Transmission Delay	90
175	<i>rE.to.</i>	Reception Timeout	90
176	<i>nu.Er.</i>	Number of Errors	90
177÷185		Reserved Parameters - Group L	90

GROUP M - *tAr* - Timer

186	<i>tAr.1</i>	Timer 1	91
187	<i>t.b.t.1</i>	Time Base Timer 1	91
188	<i>A.tAr.1</i>	Action Timer 1	91
189	<i>tAr.2</i>	Timer 2	91
190	<i>t.b.t.2</i>	Time Base Timer 2	91
191	<i>A.tAr.2</i>	Action Timer 2	92
192	<i>tAr.S.</i>	Timers Sequence	92
193÷197		Reserved Parameters - Group M	92