

VER:1.0

RTD Temperature Module
User Manual

ARRAY ELECTRONIC CO., LTD.

Contents

1 Overview.....	3
1.1 Introduction.....	3
1.2 Module configuration.....	3
1.3 Terminal arrangement.....	4
1.4 Specification and function description.....	5
1.5 Installation and Environment.....	6
1.5.1 Installation requirements.....	8
2 Communication.....	9
2.1 Baud rate setting.....	9
2.2 Station number setting.....	10
3 Application.....	11
3.1 Single module application.....	11
3.2 MODBUS communication.....	11
3.2 How to connect with PLC.....	12

1 Overview

1.1 Introduction

ARRAY RTD series temperature module has broken alarm indication and 2 voltages and 2 current outputs. At the same time, as special extended module, it adopts RS485 communication port, is based on Standard Modbus protocol, and has a wide range of uses. RTD module can be used independently, also support PLC, Human machine, all-in-one machine and other equipment that support Modbus protocol. So it is widely used in process control systems such as temperature, flow, liquid level and pressure. And meet the needs of actual industrial control better.

1.2 Module configuration

RTD series temperature module could connect with Human Machine , PLC integrated machine and other system through RS485. One equipment could connect with 16 pcs of RTD module at most, and is as Modbus slave mode in the entire system.

Specific equipment can include:

ARRAY SH-300

Others can be used as Modbus master mode operating device

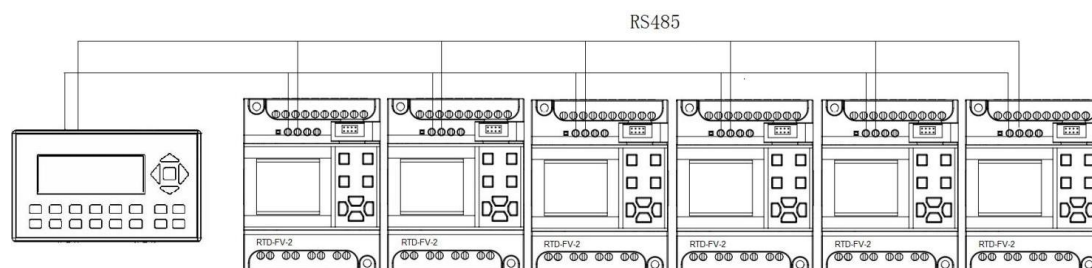

The above figure uses FAB2 communication as an example

- Communication baud rate settings are set through the LCD panel
- Module station number settings are set through the LCD panel.

1.3 Terminal arrangement

(1) The input terminal arrangement is as follows:

L+		M	SV	C1	I1	A1	C2	I2	A2
----	--	---	----	----	----	----	----	----	----

L+ M: Connection port of power input, DC12V-24V

M SV: When M and SV is shorted, Indicates that the output is an analog voltage signal

C1 I1 A1: Three-wire of thermal resistance temperature sensor signal access point CH1 (PT100 thermal resistance view)

C2 I2 A2: Three-wire of thermal resistance temperature sensor signal access point CH2 (PT100thermal resistance view)

(2) The output terminal arrangement is as follows:

- V	O1+	- V	O2+	- A	O1+	- A	O2+
-----	-----	-----	-----	-----	-----	-----	-----

-VO1+: Channel CH1 temperature signal converted to analog voltage signal DC2-10V

-VO2+: Channel CH2 temperature signal converted to analog voltage signal DC2-10V

When Input M and SV is shorted, the output signal is analog voltage signal.

-AO1+: Channel CH1 temperature signal converted to analog current signal 4-20mA

-AO2+: Channel CH2 temperature signal converted to analog current signal 4-20mA

When Input M and SV is not shorted, the output signal is analog current signal.

1.4 Specification and function description

The shape and size of RTD series temperature Module, pls kindly refer to the following figure (Unit: mm) :

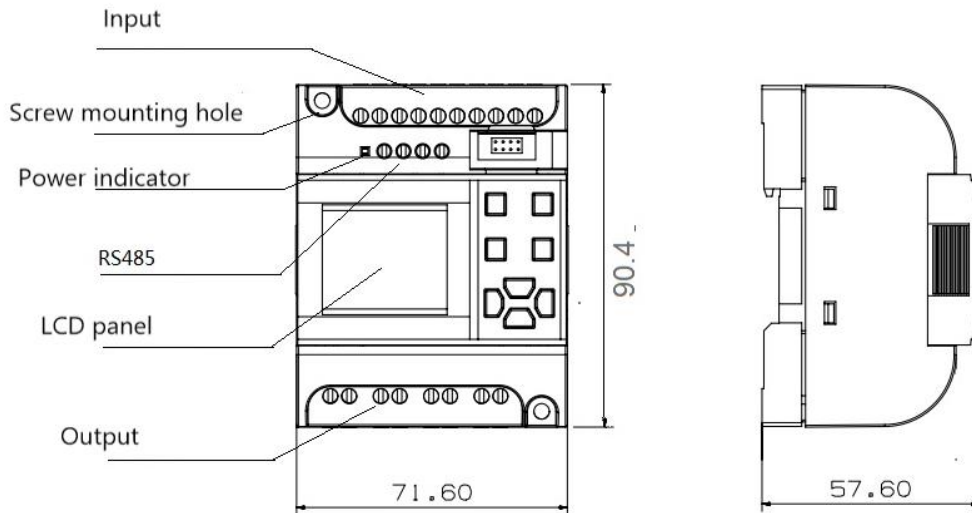

The names and functions are shown in the following table:

Name	Function
Power indicator	The red indicator is on when the power is on
Input and output terminals	Be used for connecting input and output devices
DIN Rail hook	Be used for install the module directly. Pull down the DIN rail pull hook when removing
Screw mounting hole	Screw in the screw (M3) to complete the module installation
RS485 interface	RS485 interface using Modbus communication, A is as RS485+ interface, B is as RS485- interface (A2B2 reserved)
LCD panel	Display the temperature of two input channels and set module baud rate and station number parameters

The Specifications is as below,

Power section	
Input power	DC12-24V
Input power range	Rated voltage 85%~110%
Power consumption	<5W
Input section	
Input temperature sensor	Thermal resistance PT100
Sampling period	200ms
Channel range	-200° C-850° C
Display method	LCD DISPLAY, show current temperature value
Display scale	One decimal place
Accuracy	±0.2%
Output section	
Output Type	Current output 4-20mA, two channels
	Voltage output DC2-10V, two channels
Other	
Communication	RS485 communication interface, 9600bps-115000bps transmission speed
Communication protocol	Standard Modbus RTU communication protocol
Vibration resistance	10-55Hz 10m/s ² 3 axis direction 10min
Impact resistance	Maximum 300m/s ² 3 axis 6 direction 3 times each
Operating temperature	0° C-50° C
Operating environment humidity	35% to 85%RH(No condensation)
Storage environment temperature	-20° C-65° C
Waterproof grade of Panel	IP20

1.5 Installation and Environment

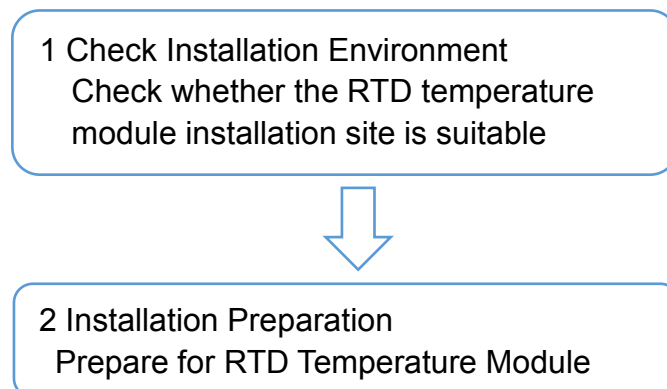









↓

3 Installation Module
Mount the module in the rail or screw

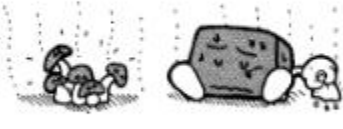
↓

4 Debugging
Check whether the RTD temperature module is installed correctly

Do not install in the following environment:

The place of direct sunlight	The place where the ambient temperature exceeds 0-55° C	The place where the ambient Humidity exceeds 35-85%RH
		
Condensation places where temperature changes drastically	Locations with corrosive gases and flammable gases	Dust, salt, iron filings and smoky places
		
The place where sites directly affected by vibration and impact	The place where spray water, oil, medicine and etc.	The place where produce strong magnetic field, strong electric field
		

1.5.1 Installation requirements

RTD series temperature modules could be used alone or connected with other devices. The installation can use 35mm DIN rail, or fix directly with M3 screws.

- Use 35mm rail mounting:

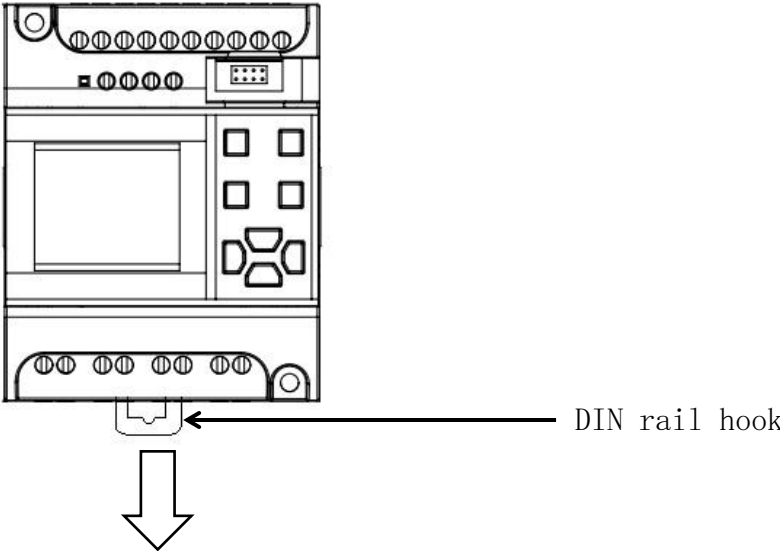

RTD temperature module can be mounted on 35mm DIN rail , When you remove, pls kindly simply pull the DIN rail's assembly hook, then the module could be removed.

- Direct installation : Special modules can also be mounted directly by screwing in the mounting holes (M3).

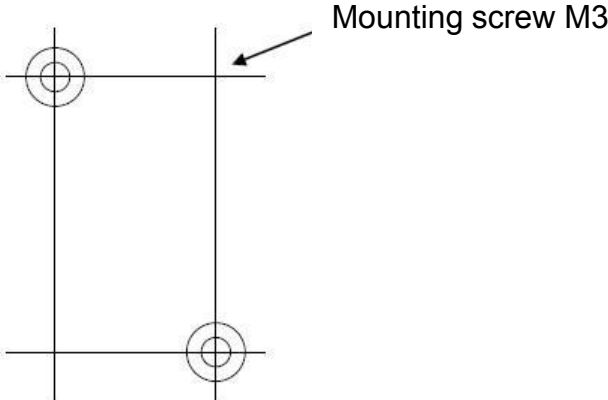

2 Communication

ARRAY RTD temperature modules is based on Standard RTU, Communication between this module and related equipment can be achieved through the settings of its communication parameters (including baud rate, data bits, stop bits, parity bits, and communication station number).

In the RTD temperature module, the baud rate and station number settings can be achieved through the LCD panel.

2.1 Baud rate setting

LCD panel is a simple Human machine. LCD panel is consisted of a liquid crystal display and eight keys (+, -, OK, ESC, left and right keys, and up and down keys). LCD display could be used for display real-time temperature of two channels (CH1 and CH2).

When RTD module is power on, LCD panel display is as follows,

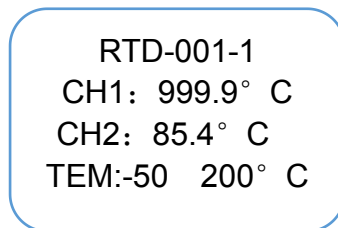

RTD-001-1
CH1: 999.9° C
CH2: 85.4° C
TEM:-50 200° C

RTD-001-1: -001: station number -1: Baud Rate(Default baud rate 19200)

Code Number	Baud Rate bps
0	19200
1	9600
2	19200
3	38400
4	57600
5	115200

CH1: 999.9° C: Channel 1 missed signal

CH2: 85.4° C: Channel 2 is detected temperature 85.4° C

TEM:-50 200° C: Two channel temperature range

1) Setting Baud rate, the method is as following,

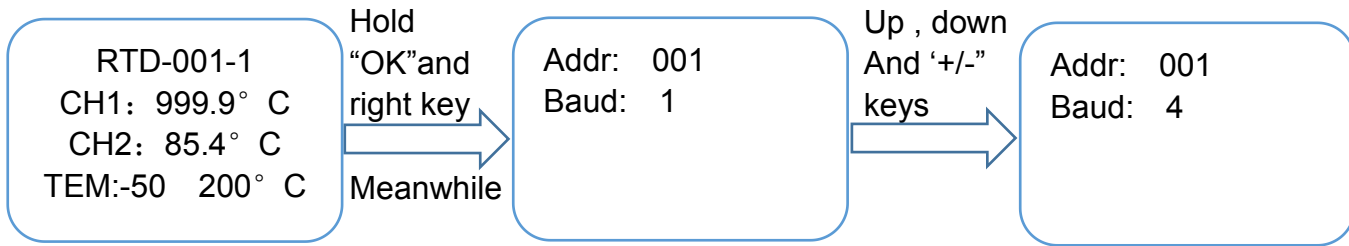

2.2 Station number setting

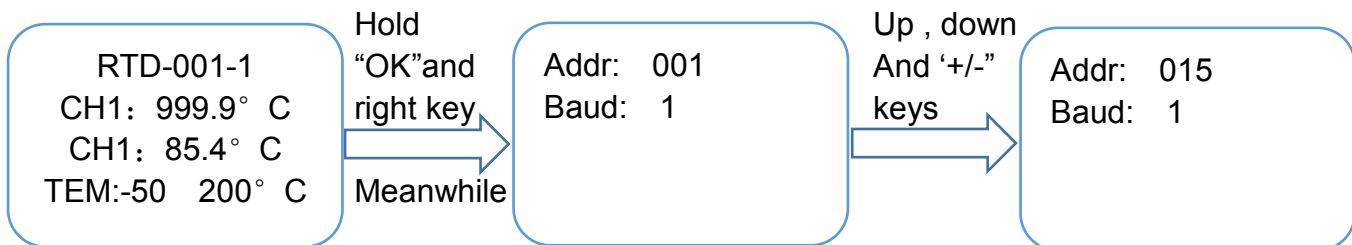

Note①: The range of station number setting is 0-255.

Note②: Up to 16 RTD series modules can be connected to one device. And in the entire system are in Modbus Slave mode.

Note③: Add repeaters to the 485 network, could connect with 256 pcs RTD module,

3 Application

3.1 Single module application

When the customer use RTD module singly, the customer could check the real temperature that the sensor detect through LCD panel. And select the type of output current or voltage by the internal operation of the module.

- 1) First of all, pls kindly access to the power L+ M,
- 2) The three-wire system of temperature sensor access to C1 I1 A1 channel (two channel we had calibrated already before ex-work),
- 3) When LCD panel show 75° C,
- 4) Can measure current across AO1 through the Multimeter's current range to 12mA.
- 5) If the input terminal M and SV is shorted, can measure voltage across VO1 using a multimeter's voltage range DC6V.

3.2 MODBUS communication

In this example, based on the 485 communication between the SH300 and the RTD temperature module, the signal value of the sensor is viewed. The detailed operation procedure is as below,

- (1) Hardware connection: Connect the A1B1 on the communication end of this module to the AB end of the SH300 communication port (485 adapters can be added), As shown below,

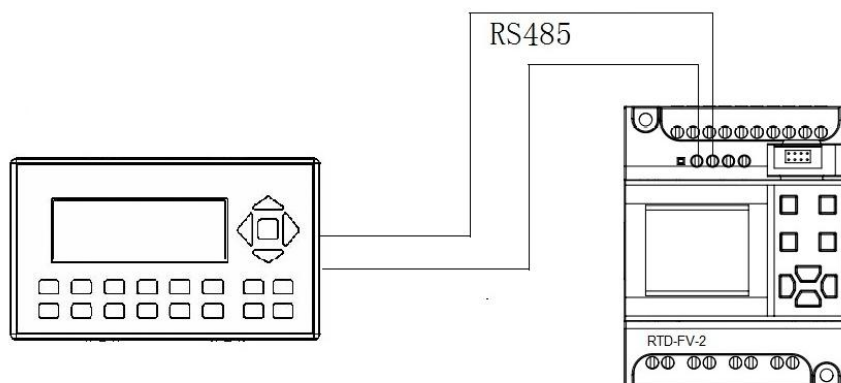

- (2) Communication parameter settings: Setting the baud rate via the LCD panel 19200bps, the station number of module is 1
- (3) Sh300 configuration: Select the type of PLC is MODBUS RTU, Baud Rate19200 and other parameter as follows,

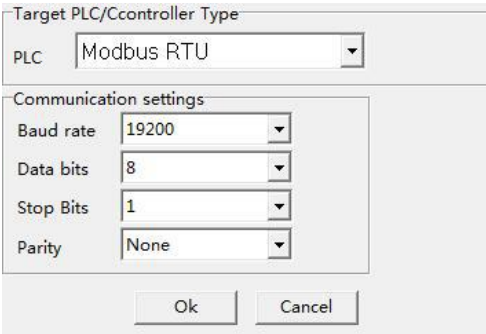

- (4) The allocation of MODBUS addresses is as follows:

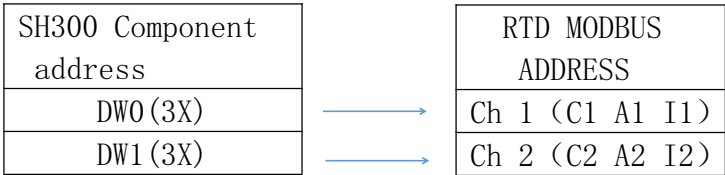

- (5) After the communication between SH300 and this module is normal,SH300 shows the temperature of CH1 and CH2 (The temperature displayed on the screen is 10 times the actual temperature)

3.2 How to connect with PLC

This module can be used with the PLC as a PLC input signal。ARRAY PLC 's input does not support temperature sensor signal, The current or voltage output signal can be fed back to the Subaru PLC input via this module. The specific operation flow is as follows:

- (1)Hardware connection: The temperature sensor access to the Channel CH1 ,Take APB-12MRDL (with analog input) as an example.APB is shorted with the power M of RTD module, the output of RTD module V1+ connect with APB's input, The output -V1 of RTD module suspended, as shown below,

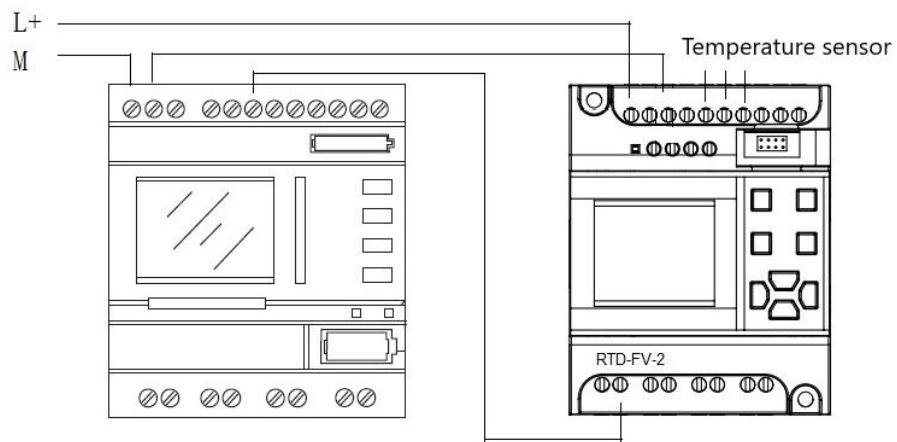

(2) Download APB's program

(3) Read signal value of analog input through APB panel (This module VO1 voltage output value)